

EVOS SMALL Plating System

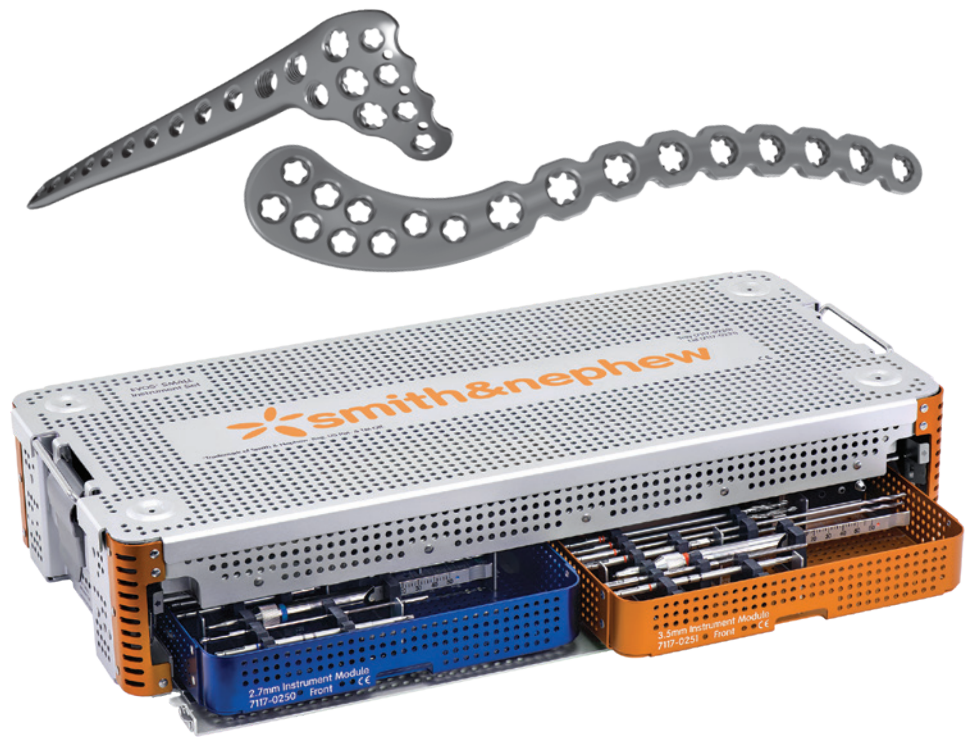

Table of contents

Overview	5
Screw Options	6
Straight Plate Options	7
Proximal Tibia Plate Options	9
Distal Tibia Plate Options	10
Fibula Plate Options	11
Distal Femur Plate Options	12
Proximal Humerus Plate Options	13
Distal Humerus Plate Options	14
Olecranon Plate Options	15
Clavicle Plate Options	16
Forearm Plate Options	17
Drill Guide Options	18
Plate Modification	20
Fracture Reduction	20
Provisional Fixation	20
Plate Placement	21
Proximal Tibia	21
3.5mm Lateral Proximal Tibia Plate	21
3.5mm Posteromedial Proximal Tibia “I” Plate	22
3.5mm Posteromedial Proximal Tibia “T” Plate	23
3.5mm Medial Proximal Tibia Plate	24
Distal Tibia	25
2.7/3.5mm Anterior Distal Tibia Plate	25
2.7/3.5mm Anterolateral Distal Tibia Plate	26
3.5mm Posterior Distal Tibia Plate	27
2.7/3.5mm Medial Distal Tibia Plate	28
Fibula	29
2.7mm, 2.7/3.5mm and 3.5mm Lateral Distal Fibula Plate	29
3.5mm Posterolateral Anti-Glide Plate	30
2.7/3.5mm Posterolateral Distal Fibula Plate	31
Distal Femur	32
3.5mm Medial Distal Femur Plate	32
3.5mm Condyle Medial Distal Femur Plate	33
Humerus	34
3.5mm Curved Proximal Humerus Plate	34
3.5mm Straight Proximal Humerus Plate	35
Greater Tuberosity Plate	36
2.7/3.5mm Medial Distal Humerus Plate	37
2.7/3.5mm Extended Medial Distal Humerus Plate	38
2.7/3.5mm Lateral Distal Humerus	39
2.7/3.5mm Extra-Articular Posterolateral Distal Humerus Plate	40
2.7/3.5mm Posterolateral Distal Humerus Plate	41
2.7/3.5mm Olecranon Plate with Tines	42
2.7/3.5mm Olecranon Plate	43

Nota Bene

The technique description herein is made available to the healthcare professional to illustrate the suggested treatment for the uncomplicated procedure. In the final analysis, the preferred treatment is that which addresses the needs of the patient.

Table of contents *continued*

Clavicle	44
2.7/3.5mm Superior Distal Clavicle Plate.....	44
3.5mm Superior Medial Clavicle Plate	45
2.7mm Superior Medial Clavicle Plate.....	46
2.7/3.5mm Inferior Distal Clavicle Plate	47
2.7mm Inferior Distal Clavicle Plate	48
2.7/3.5mm Inferior Medial Clavicle Plate	49
3.5mm Superior Midshaft Plate	50
2.7mm Superior Midshaft Plate.....	51
2.7mm Inferior Midshaft Plate	52
Forearm	53
2.7/3.5mm Extra-Articular Volar Plate.....	53
3.5mm Radial Shaft Plate	54
2.7/3.5mm Proximal Radial Shaft Plate.....	55
Screw Insertion	56
2.7mm Cortex Screws	57
2.7mm Locking Screws	61
4.0mm Osteopenia Screws	63
3.5mm Cortex Screws	65
3.5mm Locking Screws/4.7mm Locking Osteopenia Screws	68
4.7mm Osteopenia Screws.....	70
Optional Instrumentation	72
Snap In Drill Guides.....	72
Locking Screw Guides.....	74
Locking Hole Inserts	75
Closure	76
Catalog Information	77

The EVOS[®] SMALL Plating System is an expansive system with multiple fixation options including non-locking, locking and variable-angle locking. The system offers low profile constructs by featuring optimized plate contours and screw trajectories.

- 316L stainless steel
- Low profile implants
- Variable-angle locking technology
- Osteopenia screws
- Increased metaphyseal fixation*
- Intuitive instrumentation

The following technique is for informational and educational purposes only. It is not intended to serve as medical advice. It is the responsibility of treating physicians to determine and utilize the appropriate products and techniques, according to their own clinical judgment, for each of their patients. For more information on the EVOS SMALL Plating System, including its indications for use, contraindications, cleaning, sterilization and product safety information, please refer to the product's label and the Instructions for Use packaged with the product.

*Increased metaphyseal fixation compared to TC-100(Diamond trademark), PERI-LOC(Diamond trademark), and PERI-LOC VLP(Diamond trademark)

2.7mm		4.0mm		3.5mm	4.7mm		4.7mm	
Cortex	Locking	Fully Threaded Osteopenia	Partially Threaded Osteopenia	Cortex	Locking	Fully Threaded Osteopenia	Partially Threaded Osteopenia	Fully Threaded Locking Osteopenia



Thread diameter	2.7mm	2.7mm	4.0mm	4.0mm	3.5mm	3.5mm	4.7mm	4.7mm	4.7mm
Head diameter	4.5mm	4.3mm	4.5mm	4.5mm	5.6mm	5.4mm	5.6mm	5.6mm	5.4mm
Core diameter	2.0mm	2.0mm	2.0mm	2.0mm	2.5mm	2.5mm	2.5mm	2.5mm	2.5mm
Thread pitch	1.0mm	1.0mm	1.75mm	1.75mm	1.25mm	1.25mm	1.75mm	1.75mm	1.25mm
Driver	T8	T8	T8	T8	2.5mm Hex	2.5mm Hex	2.5mm Hex	2.5mm Hex	2.5mm Hex
Screw lengths	6–22mm (1mm Increments)	6–22mm (1mm Increments)	10–50mm (2mm Increments)	26–50mm (2mm Increments)	6–20mm (1mm Increments)	8–20mm (1mm Increments)	10–50mm (2mm Increments)	26–50mm (2mm Increments)	10–50mm* (2mm Increments)
	24–50mm (2mm Increments)	24–50mm (2mm Increments)	55–80mm (5mm increments)	55–80mm (5mm increments)	22–50mm (2mm Increments)	22–50mm (2mm Increments)	55–110mm* (5mm Increments)	55–110mm* (5mm Increments)	55–80mm* (5mm increments)
	55–80mm (5mm increments)	55–80mm (5mm increments)			55–110mm* (5mm Increments)	55–110mm* (5mm Increments)			
Thread length	-	-	-	40% of screw length	-	-	-	40% of screw length	

*95–110mm sterile only

2.7mm Straight Plates

Locking Recon
Plate



Locking
Compression Plate



Compression
Plate



Recon
Plate



Profile thickness
of shaft

3.2mm

3.2mm

3.5mm

3.5mm

Width of shaft

8mm

8mm

8mm

8mm

Shaft hole spacing

8mm

7.5mm

8.5mm

8mm

Length options

4H 32mm

4H 31mm

4H 33mm

4H 33mm

6H 48mm

6H 46mm

6H 50mm

6H 49mm

8H 64mm

8H 61mm

8H 67mm

8H 65mm

10H 80mm

10H 76mm

10H 84mm

10H 81mm

15H 120mm*

15H 113mm

15H 127mm

15H 121mm*

18H 144mm*

18H 136mm*

18H 153mm*

18H 145mm*

*Plates available sterile only

3.5mm Straight Plates

Locking
Compression
Plate



Locking Recon
Plate



Locking 1/3
Tubular Plate



Compression
Plate



Recon
Plate



1/3 Tubular
Plate



Profile thickness
of shaft

3.4mm

2.8mm

1.5mm

3.4mm

2.8mm

1.1mm

Width of shaft

10.7mm

10.2mm

9.5mm

10.7mm

10.2mm

9mm

Shaft hole
spacing

11.5mm

11mm

12mm

12.5mm

11mm

12mm

Length options

4H 47mm*

4H 44mm*

2H 22mm*

4H 52mm

4H 44mm

2H 22mm*

6H 70mm

6H 66mm*

4H 46mm*

6H 77mm

6H 66mm

4H 46mm*

7H 81mm

8H 88mm*

6H 70mm

7H 90mm

8H 88mm

6H 70mm

8H 93mm

10H 110mm*

7H 82mm

8H 102mm

10H 110mm

7H 82mm

10H 116mm

12H 132mm*

8H 94mm

10H 127mm

12H 132mm*

8H 94mm

12H 139mm

14H 154mm*

10H 118mm

12H 152mm

14H 154mm*

10H 118mm

14H 162mm

16H 176mm*

12H 142mm*

14H 177mm

16H 176mm*

12H 142mm*

16H 185mm*

18H 198mm*

16H 202mm*

18H 198mm*

18H 208mm*

20H 220mm*

18H 227mm*

20H 220mm*

20H 231mm*







22H 242mm*

20H 252mm*

22H 242mm*







*Plates available sterile only

3.5mm Proximal Tibia Plates

	Lateral Proximal Tibia		Medial Proximal Tibia		Posteromedial Proximal Tibia "T"		Posteromedial Proximal Tibia "I"
	Partial Articular Plate	Standard Plate	Partial Articular Plate	Standard Plate	Partial Articular Plate	Standard Plate	Partial Articular Plate
							
Left/right specific	Yes	Yes	Yes	Yes	Yes	Yes	Yes
Profile thickness of head	1.8mm	1.9mm	1.5mm	2.5mm	2mm	2mm	1.8mm
Width of head	31.9mm	32.3mm	25mm	25mm	32.5mm	32.5mm	21.8mm
Profile thickness of shaft	2mm	3.6mm	2mm	3.4mm	2mm	3.4mm	2mm
Width of shaft	11.2mm	11.5mm	10.9mm	10.9mm	10.9mm	11.4mm	10.9mm
Shaft hole spacing	11mm	11mm	11mm	11mm	11mm	11mm	11mm
Length options	4H 70mm 6H 91mm	4H 70mm 6H 91mm 8H 113mm 10H 134mm 13H 167mm 16H 200mm 18H 221mm* 20H 243mm* 22H 265mm* 24H 287mm*	4H 75mm 8H 117mm	8H 117mm 10H 138mm 13H 170mm 16H 201mm	4H 71mm 7H 103mm	7H 104mm 10H 137mm* 13H 170mm*	5H 78mm 8H 111mm





*Plates available sterile only

2.7/3.5mm Distal Tibia Plates

	Medial Distal Tibia		Anterior Distal Tibia	Anterolateral Distal Tibia		Posterior Distal Tibia	
	Partial Articular Plate	Standard Plate	Partial Articular Plate	Partial Articular Plate	Standard Plate	Partial Articular Plate	Standard Plate
							
Left/right specific	Yes	Yes	No	Yes	Yes	Yes	Yes
Profile thickness of head	1.7mm	2.7mm	1.4mm	1.7mm	1.8mm	1.5mm	2.4mm
Width of head	17.4mm	18.8mm	32mm	34.4mm	35mm	19mm	19.4mm
Profile thickness of shaft	2mm	3.4mm	1.5mm	2mm	3.5mm	1.5mm	3.5mm
Width of shaft	12.2mm	11.4mm	10.9mm	11.2mm	12.7mm	10.9mm	11.4mm
Shaft hole spacing	11mm	11mm	11mm	11mm	11mm	11mm	11mm
Length options	3H 64mm 6H 97mm 9H 130mm	9H 130mm 12H 162mm 15H 195mm 18H 228mm* 21H 261mm*	3H 74mm 6H 107mm 9H 140mm	6H 87mm 9H 120mm	8H 120mm 11H 153mm 14H 186mm 17H 219mm* 20H 252mm*	3H 63mm 6H 96mm	6H 98mm 9H 131mm 12H 163mm* 15H 196mm*

*Plates available sterile only

2.7mm, 2.7/3.5mm, 3.5mm Fibula Plates

	Lateral Distal Fibula			Posterolateral Distal Fibula	
	2.7mm Plate	2.7/3.5mm Plate	3.5mm Plate	3.5mm Anti-glide Plate	2.7/3.5mm Plate
					
Left/right specific	Yes	Yes	Yes	Yes	Yes
Profile thickness of head	1.5mm	1.7mm	1.7mm	-	1.8mm
Width of head	13.9mm	16.3mm	16.3mm	-	8mm
Profile thickness of shaft	1.5mm	2mm	2mm	1.5mm	2mm
Width of shaft	8.6mm	10mm	10mm	9.5mm	10mm
Shaft hole spacing	7mm	11mm	11mm	11mm	11mm
Length options	5H 61mm 8H 82mm 11H 103mm*	3H 59mm 5H 81mm 7H 103mm 9H 125mm 11H 147mm 13H 169mm* 16H 202mm*	3H 59mm 5H 81mm 7H 103mm 9H 125mm 11H 147mm 13H 169mm* 16H 202mm*	5H 58mm 6H 69mm 7H 80mm	5H 93mm 7H 115mm 9H 137mm 11H 159mm 14H 192mm*

*Plates available sterile only

3.5mm Distal Femur Plates

	Medial Distal Femur	Condylar Medial Distal Femur
	3.5mm Plate	3.5mm Plate



Left/right specific	Yes	Yes
Profile thickness of head	2.0mm	2.0mm
Width of head	18.0mm	21.0mm
Profile thickness of shaft	2.0mm	2.0mm
Width of shaft	11.0mm	11.0mm
Shaft hole spacing	11.0mm	11.0mm
Length options	5H 90mm	5H 115mm

3.5mm Proximal Humerus Plates





	Curved Proximal Humerus	Straight Proximal Humerus	Greater Tuberosity
--	-------------------------	---------------------------	--------------------



Left/right specific	Yes	No	No
Profile thickness of head	3mm	3mm	2mm
Profile thickness of shaft	3mm	3mm	2mm
Width of shaft	12mm	12mm	11mm
Shaft hole spacing	11mm	11mm	11mm
Length options	4H 92mm 6H 114mm 9H 147mm 12H 180mm 15H 213mm 18H 246mm*	3H 93mm 5H 115mm	5H 62mm 7H 84mm

*Plates available sterile only

2.7/3.5mm Distal Humerus Plates

	Medial Distal Humerus	Extended Medial Distal Humerus	Lateral Distal Humerus	Posterolateral Distal Humerus	Extra-Articular Posterolateral Distal Humerus
					
Left/right specific	Yes	Yes	Yes	Yes	Yes
Profile thickness of head	3mm	3mm	2mm	2mm	2mm
Profile thickness of shaft	3mm	3mm	3mm	3mm	4mm
Width of shaft	11mm	11mm	11mm	11mm	12mm
Shaft hole spacing	11mm	11mm	11mm	11mm	11mm
Length options	3H 80mm 5H 102mm 7H 124mm 9H 146mm 12H 179mm*	7H 130mm*	7H 90mm 9H 112mm 11H 134mm 13H 156mm*	6H 85mm 8H 107mm 10H 129mm 13H 162mm 17H 206mm*	12H 151mm 16H 195mm 20H 239mm 25H 294mm*

*Plates available sterile only

2.7/3.5mm Olecranon Plates

	Olecranon with Tines	Olecranon without Tines
--	----------------------	-------------------------



Left/right specific	Yes	Yes
Profile thickness of head	2.5mm	2.5mm
Profile thickness of shaft	3mm	3mm
Width of shaft	10.5mm	10.5mm
Shaft hole spacing	11mm	11mm
Length options	2H 61mm 4H 82mm 7H 114mm 10H 147mm* 13H 179mm*	3H 61mm 5H 83mm 8H 114mm 11H 147mm* 14H 180mm*

Clavicle Plates

Superior Distal Plate	Superior Medial Plate	Inferior Distal Plate	Inferior Medial Plate	2.7mm Superior Medial Plate	2.7mm Inferior Distal Plate	3.5 mm Superior Midshaft	2.7mm Superior Midshaft	2.7mm Inferior Midshaft
-----------------------	-----------------------	-----------------------	-----------------------	-----------------------------	-----------------------------	--------------------------	-------------------------	-------------------------

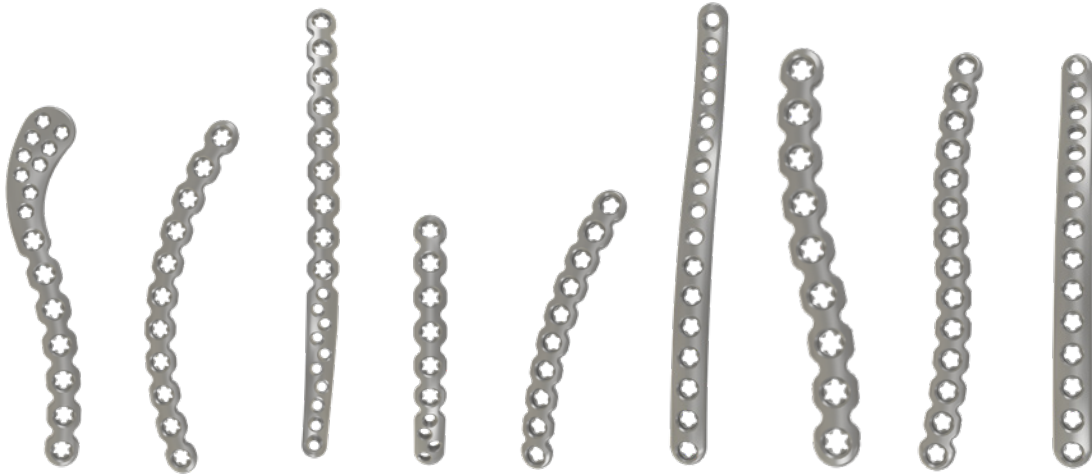

Left/right specific	Yes	No	Yes	No	No	Yes	Yes	Yes	No
Profile thickness of head	2.5mm	3mm	3mm	3mm	2.4mm	2.4mm	3mm	3mm	2mm
Profile thickness of shaft	3mm	3mm	3mm	3mm	2.4mm	2.4mm	3mm	2.4mm	2.4mm
Width of shaft	10.5mm	10.5mm	10.5mm	10.5mm	8mm	8.5mm	12mm	12mm	11mm
Shaft hole spacing	11mm	11mm	11mm	11mm	7mm	7mm	11mm	11mm	11mm
Length options	5H 89mm 7H 111mm 9H 133mm 11H 154mm*	8H 87mm 11H 117mm	3H 86mm 5H 107mm 7H 129mm 9H 151mm*	6H 86mm 9H 115mm*	10H 67mm 13H 87mm 16H 105mm	3H 82mm 7H 116mm 13H 151mm	8H 86mm 9H 97mm* 10H 108mm 12H 130mm	14H 93mm 16H 107mm* 18H 120mm	8H 99mm 11H 120mm

*Plates available sterile only

Forearm Plates







	Extra-Articular Volar Distal Radius	Radial Shaft	Proximal Radial Shaft
--	-------------------------------------	--------------	-----------------------



Left/right specific	Yes	No	Yes
Profile thickness of head	1.6mm	-	3.5mm
Profile thickness of shaft	3.5mm	3.5mm	3.5mm
Width of shaft	11.2mm	11.2mm	11.2mm
Shaft hole spacing	12mm	12mm	12mm
Length options	10H 138mm	8H 98mm 10H 122mm 12H 146mm 14H 169mm 16H 193mm	5H 95mm 8H 130mm

*Plates available sterile only

2.7mm Drill Guide Module

Drill Guides	Technique	Outside of plate	Variable-angle holes	Threaded holes	Non-threaded holes	Drill
2.0 x 2.7mm Drill Guide 	Independent Lag Screw - Cortex Screws *Axial Compression -Cortex Screws	✓		✓*	✓*	2.0mm Short, 2.7mm Over-Drill, Short
2.0mm VA Drill Guide 	On/off axis - Cortex Screws - Locking Screws - Osteopenia Screws		✓			2.0mm Short
2.0mm Neutral x Compression 	Neutral/Compression - Cortex Screws				✓	2.0mm Short
2.0mm Locking Drill Guide 	On axis - Cortex Screws - Locking Screws - Osteopenia Screws			✓		2.0mm Long
2.0mm Serrated Drill Guide, Long 	Independent Lag Screw - Cortex Screws *Axial Compression - Cortex Screws	✓		✓*	✓*	2.0mm Long
2.7mm Serrated Drill Guide, Long 	Independent Lag Screw - Cortex Screws	✓				2.7mm Over-Drill, Short
2.0mm Drill Guide, Long 	On/off axis - Cortex Screws On axis - Locking Screws - Osteopenia Screws			✓	✓	2.0mm Long

3.5mm Drill Guide Module







Drill Guides	Technique	Outside of plate	Variable-angle holes	Threaded holes	Non-threaded holes	Drill
2.5 x 3.5mm Drill Guide 	Independent Lag Screw - Cortex Screws *Axial Compression - Cortex Screws	✓	✓*	✓*	✓*	2.5mm Short 3.5mm Over-Drill, Short
2.5mm VA Drill Guide 	On/off axis - Cortex Screws - Locking Screws - Osteopenia Screws		✓			2.5mm Short
2.5mm Neutral x Compression 	Neutral/Compression - Cortex Screws				✓ *Non-Locking Compression plates only.	2.5mm Short
2.5mm Locking Drill Guide 	On axis - Cortex Screws - Locking Screws - Osteopenia Screws			✓		2.5mm Long
2.5mm Serrated Drill Guide, Long 	Independent Lag Screw - Cortex Screws *Axial Compression - Cortex Screws	✓	✓*	✓*	✓*	2.5mm Long
3.5mm Serrated Drill Guide, Long 	Independent Lag Screw - Cortex Screws	✓				3.5mm Over-Drill, Short
2.5mm Drill Guide, Long 	On/off axis - Cortex Screws *On Axis - Locking Screws - Osteopenia Screws		✓	✓*		2.5mm Long

Plate Modification

Minor plate contouring can be accomplished by using the plate bending irons or the plate bending pliers.

Note: Plate contouring can affect the functionality of the locking mechanism. Avoid bending or contouring directly over a hole that will eventually be used for a locking screw.



EVOS° SMALL Plate Bending Pliers



EVOS SMALL 2.7/3.5mm Recon Plate Bending Pliers*
*Note: Recon plates only

Fracture Reduction

Articular fracture components must be anatomically reduced prior to plate application and screw insertion. Reduction aids should be placed so as not to interfere with final plate placement. Reduce and provisionally secure fragments using K-Wires or reduction forceps. Hohmann retractors are provided within the set and should be utilized to protect soft tissue structures.

K-Wires:

- 1.25mm Trocar Tip K-Wire, 150mm
- 1.6mm Trocar Tip K-Wire, 150mm
- 2.0mm Trocar Tip K-Wire, 150mm

Reduction Forceps:

- Reduction Forceps with Points, Broad
- Reduction Forceps with Serrated Jaw
- Reduction Forceps Bowed, 205mm

Provisional Fixation

Optional

Position the plate to the desired location and provisionally fix the plate to the bone using the provisional fixation pins. There are two diameters of provisional fixation pins:

Plate size	PF Pin size
2.7mm	2.0mm x 14mm, 25mm and 40mm
3.5mm	2.5mm x 14mm, 25mm and 40mm

Provisional Fixation pins are self-drilling and self-tapping. They should be inserted by power, however final tightening should always be completed by hand.

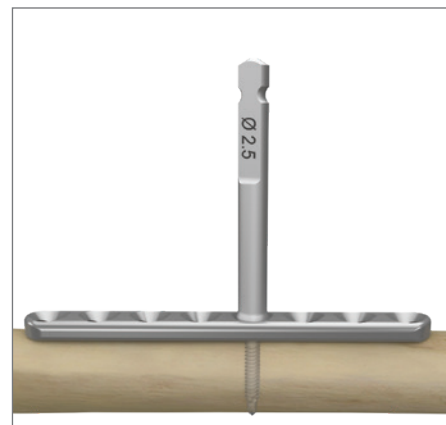



3.5mm Lateral Proximal Tibia Plate

Position the plate, as desired, along the lateral aspect of the proximal tibia. A posterior tilt aligns the proximal rows of screws with the posterior slope of the lateral tibial condyle. Plate coverage extending down the shaft is maximized by a sagittal curve in the plate's proximal segment. A proximal row of scallops facilitates external lag screw placement without compromising plate position.

Plate placement should be adjusted to the best fit position on each individual patient. Fluoroscopy can be utilized to confirm plate position.

Provisionally fix the plate to bone using K-Wires, reduction clamps and/or provisional fixation pins and proceed with screw insertion as desired.

Fluoroscopy should be utilized to verify screw path placement during drilling of the most proximal cluster of screws in the plate to prevent joint penetration.



Indicated for AO/OTA
Fracture Classification
Type B fractures

Note: The EVOS[®] SMALL Preoperative Templates are available to assist with preoperative radiographic planning. Please reference catalog information for item number.



3.5mm Posteromedial Proximal Tibia “I” Plate

Position the plate to sit along the most proximal posteromedial aspect of the tibia with the top of the plate just below the articular surface of the tibial plateau.

Plate placement should be adjusted to the best fit position on each individual patient. Fluoroscopy can be utilized to confirm plate position.

Provisionally fix the plate to bone using K-Wires, reduction clamps and/or provisional fixation pins and proceed with screw insertion as desired.

Fluoroscopy should be utilized to verify screw path placement during drilling of the most proximal cluster of screws in the plate to prevent joint penetration.



Indicated for AO/OTA
Fracture Classification
Type B fractures

Note: The EVOS[®] SMALL Preoperative Templates are available to assist with preoperative radiographic planning. Please reference catalog information for item number.



3.5mm Posteromedial Proximal Tibia “T” Plate

Position the plate to sit along the posteromedial aspect of the proximal tibia. Scallops at the top of the plate facilitate lag screw placement for joint surface reconstruction without compromising plate position.

Plate placement should be adjusted to the best fit position on each individual patient. Fluoroscopy can be utilized to confirm plate position.

Provisionally fix the plate to bone using K-Wires, reduction clamps and/or provisional fixation pins and proceed with screw insertion as desired.

Fluoroscopy should be utilized to verify screw path placement during drilling of the most proximal cluster of screws in the plate to prevent joint penetration.

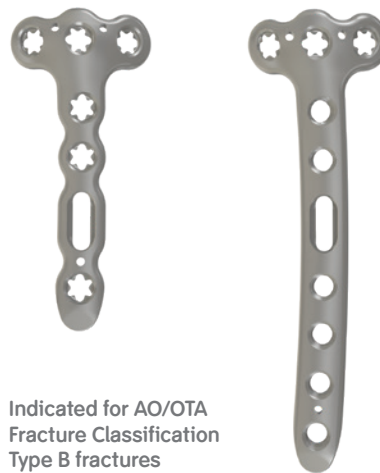

Note: The EVOS[®] SMALL Preoperative Templates are available to assist with preoperative radiographic planning. Please reference catalog information for item number.



3.5mm Medial Proximal Tibia Plate

Position the plate to sit along the anteromedial aspect of the proximal tibia. Plate coverage extending down the shaft is maximized by a sagittal curve in the plate's proximal segment. Scallops at the top of the plate facilitate lag screw placement for joint surface reconstruction without compromising plate position.

Plate placement should be adjusted to the best fit position on each individual patient. Fluoroscopy can be utilized to confirm plate position. Provisionally fix the plate to bone using K-Wires, reduction clamps and/or provisional fixation pins and proceed with screw insertion as desired.

Fluoroscopy should be utilized to verify screw path placement during drilling of the most proximal cluster of screws in the plate to prevent joint penetration.

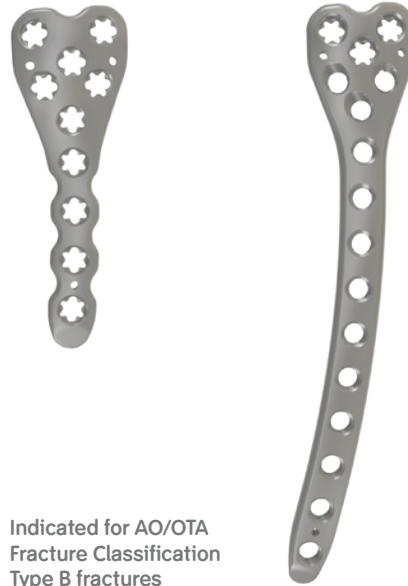

Indicated for AO/OTA
Fracture Classification
Type B fractures

Note: The EVOS[®] SMALL Preoperative Templates are available to assist with preoperative radiographic planning. Please reference catalog information for item number.



2.7/3.5mm Anterior Distal Tibia Plate

Position the plate to sit along the anterior aspect of the distal tibia with its distal tip resting just superior to the tibial plafond. Distal scallops facilitate lag screw placement without compromising plate position.

Plate placement should be adjusted to the best fit position on each individual patient. Fluoroscopy can be utilized to confirm plate position. Provisionally fix the plate to bone using K-Wires, reduction clamps and/or provisional fixation pins and proceed with screw insertion as desired.

Fluoroscopy should be utilized to verify screw path placement during drilling of the most distal cluster of screws in the plate to prevent joint penetration.



Indicated for AO/OTA Fracture Classification
Type B fractures

Note: The EVOS[®] SMALL Preoperative Templates are available to assist with preoperative radiographic planning. Please reference catalog information for item number.



2.7/3.5mm Anterolateral Distal Tibia Plate

Position the plate to sit along the anterior aspect of the distal tibia with its distal tip resting just superior to the tibial plafond. Distal scallops facilitate lag screw placement without compromising plate position. Proximally the plate sits on the lateral shaft of the tibia.

Plate placement should be adjusted to the best fit position on each individual patient. Fluoroscopy can be utilized to confirm plate position. Provisionally fix the plate to bone using K-Wires, reduction clamps and/or provisional fixation pins and proceed with screw insertion as desired.

Fluoroscopy should be utilized to verify screw path placement during drilling of the most distal cluster of screws in the plate to prevent joint penetration.

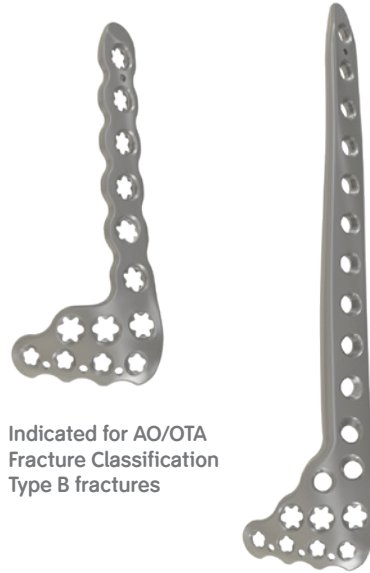

Indicated for AO/OTA
Fracture Classification
Type B fractures

Note: The EVOS[®] SMALL Preoperative Templates are available to assist with preoperative radiographic planning. Please reference catalog information for item number.



3.5mm Posterior Distal Tibia Plate

Position the plate to sit along the posterior aspect of the distal tibia with its distal tip resting just superior to the tibial plafond. Distal scallops facilitate lag screw placement without compromising plate position.

Plate placement should be adjusted to the best fit position on each individual patient. Fluoroscopy can be utilized to confirm plate position.

Provisionally fix the plate to bone using K-Wires, reduction clamps and/or provisional fixation pins and proceed with screw insertion as desired.

Fluoroscopy should be utilized to verify screw path placement during drilling of the most distal cluster of screws in the plate to prevent joint penetration.



Indicated for AO/OTA
Fracture Classification
Type B fractures



Note: The EVOS[®] SMALL Preoperative Templates are available to assist with preoperative radiographic planning. Please reference catalog information for item number.



2.7/3.5mm Medial Distal Tibia Plate

Position the plate to sit along the medial aspect of the distal tibia with the distal screw cluster engaging the medial malleolus. Scallops have been placed in the anterior aspect of the plate to allow room for clamps, K-Wires and independent lag screws.

Plate placement should be adjusted to the best fit position on each individual patient. Fluoroscopy can be utilized to confirm plate position.

Provisionally fix the plate to bone using K-Wires, Ball Spike Reduction Clamps and/or Provisional Fixation Pins and proceed with screw insertion as desired.

Fluoroscopy should be utilized to verify screw path placement during drilling of the most distal cluster of screws in the plate to prevent joint penetration.



Note: The EVOS[®] SMALL Preoperative Templates are available to assist with preoperative radiographic planning. Please reference catalog information for item number.



2.7mm, 2.7/3.5mm and 3.5mm Lateral Distal Fibula Plate

Position the plate to sit along the lateral aspect of the distal fibula with the distal screw cluster engaging the lateral malleolus.

Plate placement should be adjusted to the best fit position on each individual patient. Fluoroscopy can be utilized to confirm plate position.

Provisionally fix the plate to bone using K-Wires, Ball Spike Reduction Clamps and/or Provisional Fixation Pins and proceed with screw insertion as desired.

Fluoroscopy should be utilized to verify screw path placement during drilling of the most distal cluster of screws in the plate to prevent joint penetration.

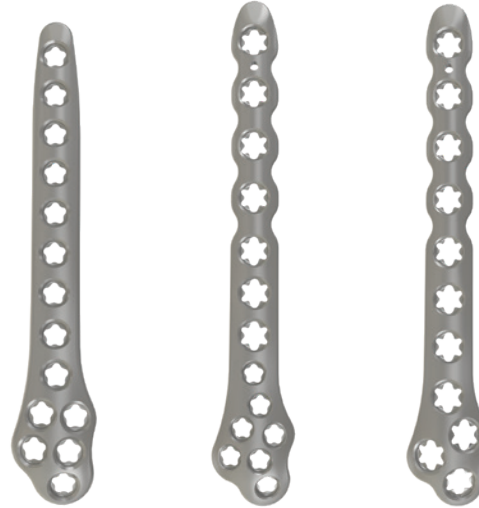

2.7mm

2.7/3.5mm

3.5mm

Note: The EVOS[®] SMALL Preoperative Templates are available to assist with preoperative radiographic planning. Please reference catalog information for item number.



3.5mm Posterolateral Anti-Glide Plate

Position the plate to sit along the posterolateral aspect of the distal fibula. The proximal portion of the plate is tapered to assist in sub-muscular insertion while the distal portion of the plate features rounded distal edges to minimize peroneal nerve irritation. The scallops along the edge of the plate are meant to sit anteriorly and are designed to facilitate syndesmotic screw placement.



Plate placement should be adjusted to the best fit position on each individual patient. Fluoroscopy can be utilized to confirm plate position. Provisionally fix the plate to bone using K-Wires, Ball Spike Reduction Clamps and/or Provisional Fixation Pins and proceed with screw insertion as desired.

Note: The EVOS[®] SMALL Preoperative Templates are available to assist with preoperative radiographic planning. Please reference catalog information for item number.



2.7/3.5mm Posterolateral Distal Fibula Plate

The plate is designed to sit on the posterior aspect of the fibula distally and has a gradual contour that places it on the lateral aspect of the fibula more proximally. The posterolateral aspect of the fibula must be dissected to the point in which the peroneal tendon can be identified at the distal end of the fibula.

Note: Patient anatomical variation may place the plate into the posterolateral aspect of the distal fibula in some patients.

Plate placement should be adjusted to the best fit position on each individual patient. Fluoroscopy can be utilized to confirm plate position. Provisionally fix the plate to bone using K-Wires, Ball Spike Reduction Clamps and/or Provisional Fixation Pins and proceed with screw insertion as desired.

Fluoroscopy should be utilized to verify screw path placement during drilling of the most distal cluster of screws in the plate to prevent joint penetration.



Note: The EVOS[®] SMALL Preoperative Templates are available to assist with preoperative radiographic planning. Please reference catalog information for item number.



3.5mm Medial Distal Femur Plate

Position the plate by matching the contour of the plate to the distal portion of the medial femur. The distal portion of the plate widens to allow multiple points of fixation in this region and is designed to fit the distal medial femur posterior to the articular surface and anterior to the medial epicondyle. The distal extent of the plate is meant to extend to, but generally not beyond, the medial epicondyle. The proximal portion of the plate aligns with the long axis of the femur on the medial or anterior/medial surface of the distal shaft





3.5mm Condylar Medial Distal Femur Plate

Position the plate by matching the contour of the plate to the distal portion of the medial femur. The distal portion of the plate widens and curves to allow multiple points of fixation extending distal to the medial epicondyle. This portion of the plate is designed to fit the distal medial femur posterior to the articular surface and anterior to the medial epicondyle with the very distal portion of the plate curving distal and posterior, essentially wrapping around the epicondylar region. The proximal portion of the plate aligns with the long axis of the femur on the medial or anterior/medial surface of the distal shaft





3.5mm Curved Proximal Humerus Plate

Position the plate approximately 1cm distal to the rotator cuff attachment on the superior aspect of the greater tuberosity. The plate should sit posterolateral to the bicipital groove. Avoid placement too far proximally on the humerus as this increases the risk of subacromial impingement. Similarly, placement too low may compromise screw purchase in the humeral head.

Plate placement should be adjusted to best fit position on each individual patient. Fluoroscopy can be utilized to confirm plate position. Provisionally fix the plate to bone using K-wires, reduction clamps and/or provisional fixation pin and proceed with screw insertion as desired.

Fluoroscopy should be utilized to verify screw path placement during drilling of the most proximal cluster of screws in plate to prevent joint penetration.

Note: To reduce the risk of damage to the suture, the sutures should span between two holes and tie over a middle bridge.



Note: The EVOS° SMALL Preoperative Templates are available to assist with preoperative radiographic planning. Please reference catalog information for item number.



3.5mm Straight Proximal Humerus Plate

Position the plate approximately 1cm distal to the rotator cuff attachment on the superior aspect of the greater tuberosity. The plate should sit posterolateral to the bicipital groove and deep to the deltoid muscle and axillary nerve. Avoid placement too far proximal on the humerus as this increases the risk of subacromial impingement. Similarly, placement too low may compromise screw purchase in the humeral head.

Plate placement should be adjusted to best fit position on each individual patient. Fluoroscopy can be utilized to confirm plate position. Provisionally fix the plate to bone using K-wires, reduction clamps and/or provisional fixation pin and proceed with screw insertion as desired.

Fluoroscopy should be utilized to verify screw path placement during drilling of the most proximal cluster of screws in plate to prevent joint penetration.

Note: To reduce the risk of damage to the suture, the sutures should span between two holes and tie over a middle bridge.



Note: The EVOS° SMALL Preoperative Templates are available to assist with preoperative radiographic planning. Please reference catalog information for item number.



Greater Tuberosity Plate

The plate should sit posterolateral to the bicipital groove and should engage the rotator cuff attachment on the superior aspect of the greater tuberosity. The plate tines should engage to rotator cuff. Avoid placement too far proximal on the humerus as this increases the risk of subacromial impingement. Similarly, placement too low may compromise greater tuberosity stabilization.

Plate placement should be adjusted to best fit position on each individual patient. Fluoroscopy can be utilized to confirm plate position. Provisionally fix the plate to bone using K-wires, reduction clamps and/or provisional fixation pin and proceed with screw insertion as desired.

Fluoroscopy should be utilized to verify screw path placement during drilling.

Note: To reduce the risk of damage to the suture, the sutures should span between two holes and tie over a middle bridge.



Note: The EVOS[®] SMALL Preoperative Templates are available to assist with preoperative radiographic planning. Please reference catalog information for item number.



2.7/3.5mm Medial Distal Humerus Plate

The head of the plate should be aligned with the distal surface of the humerus prior to placement of the proximal aspect of the plate on the shaft.

Plate should rest on the medial column and matched to the patients native anatomy to allow for placement of mediolateral screw trajectories in relation to the joint line.

Fluoroscopy and anatomical landmarks should be utilized to identify the correct position of the medial distal humerus plate. Note anatomical variations are common between patients and slight contouring of plates may be required.

Plate placement should be adjusted to the best fit position on each individual patient. Fluoroscopy can be utilized to confirm plate position. Provisionally fix the plate to bone using K-wires, Ball Spike Reduction Clamps and/or Provisional Fixation Pins and proceed with screw insertion as desired.

Fluoroscopy should be utilized to verify screw path placement during drilling of the most distal cluster of screws in the plate to prevent joint penetration.



Note: The EVOS[®] SMALL Preoperative Templates are available to assist with preoperative radiographic planning. Please reference catalog information for item number.



2.7/3.5mm Extended Medial Distal Humerus Plate

The extended medial distal humerus plate allows for additional ascending screw placement from a distal to proximal aspect of the periarticular surface of the humerus.

The head of the plate should be aligned with the distal surface of the humerus prior to placement of the proximal aspect of the plate on the shaft.

Plate should rest on the medial column of the humerus and wrap around the medial epicondyle.

Fluoroscopy and anatomical landmarks should be utilized to identify the correct position of the medial distal humerus plate. Note anatomical variations are common between patients and slight contouring of plates may be required.

Fluoroscopy should be utilized to verify screw path placement during drilling of the most distal cluster of screws in the plate to prevent joint penetration.



Note: The EVOS[®] SMALL Preoperative Templates are available to assist with preoperative radiographic planning. Please reference catalog information for item number.



2.7/3.5mm Lateral Distal Humerus

The plate is designed to fit the lateral ridge of the distal humerus and the most distal screw hole can run parallel to the anatomical axis of the joint.

The anatomic twist in the plate results in the proximal aspect of the plate being on the dorsolateral aspect of the shaft of the humerus with longer plate lengths.

The radial nerve should be visualized and protected during plate placement and instrumentation.

Fluoroscopy and anatomical landmarks should be utilized to identify the correct position of the medial distal humerus plate. Note anatomical variations are common between patients and slight contouring of plates may be required.

Fluoroscopy should be utilized to verify screw path placement during drilling of the most distal cluster of screws in the plate to prevent joint penetration.



Note: The EVOS[®] SMALL Preoperative Templates are available to assist with preoperative radiographic planning. Please reference catalog information for item number.



2.7/3.5mm Extra-Articular Posterolateral Distal Humerus Plate

The Extra-Articular Distal Humerus plate is designed to fit the lateral column of the humerus distally and contoured to fit the central aspect of the posterior portion of the humerus. Due to normal anatomic variability, it is not uncommon to slightly contour the plate in the sagittal plane. Careful attention should be paid on not placing the plate in the region of the olecranon fossa, which could potentially inhibit elbow extension.

Fluoroscopy should be utilized to verify screw path placement during drilling of the most distal cluster of screws in the plate to prevent joint penetration.



Note: The EVOS[®] SMALL Preoperative Templates are available to assist with preoperative radiographic planning. Please reference catalog information for item number.



2.7/3.5mm Posterolateral Distal Humerus Plate

The posterolateral humerus plate is designed to be placed on the dorsal aspect of the capitulum. The plate position should be adjusted proximally and distally to allow for distal screw placement in the capitulum without inhibiting elbow extension and abutting the radial head with terminal extension. Furthermore, the plate position should be adjusted in the medial to lateral direction to avoid any overlap with the olecranon fossa.



Fluoroscopy can be utilized to verify plate position prior to placement of screws. The lateral radiograph is helpful to determine the proximal and distal position of the plate. The most common error is the placement of the plate too proximally.

Fluoroscopy should be utilized to verify screw path placement during drilling of the most distal cluster of screws in the plate to prevent joint penetration.

Note: The EVOS[®] SMALL Preoperative Templates are available to assist with preoperative radiographic planning. Please reference catalog information for item number.



2.7/3.5mm Olecranon Plate with Tines

Apply the appropriate length plate to the dorsal aspect of the olecranon and proximal ulna. The plate is contoured to sit on the most dorsal ulnar ridge. Proximally the plate sits on top of the triceps tendon. Elevators and/or clamps can be utilized to bring the plate down to bone. Alternatively, unicortical non-locking screws or provisional fixation pins can be placed into the apex of the plate to bring the proximal aspect of the plate down to bone or distally along the shaft.



Fluoroscopy should be utilized to verify screw path placement during drilling of the most distal cluster of screws in the plate to prevent joint penetration.

Note: To reduce the risk of damage to the suture, the sutures should span between two holes and tie over a middle bridge.

Note: The EVOS[®] SMALL Preoperative Templates are available to assist with preoperative radiographic planning. Please reference catalog information for item number.



2.7/3.5mm Olecranon Plate

Apply the appropriate length plate to the dorsal aspect of the olecranon and proximal ulna. The triceps tendon will need to be incised longitudinally at the tip of the olecranon to make a pocket for the proximal aspect of the plate. Distally the plate is contoured to sit on the most dorsal ulnar ridge. Elevators and/or clamps can be utilized to bring the plate down to bone. Alternatively unicortical non-locking screws or provisional fixation pins can be placed into the apex of the plate to bring the proximal aspect of the plate down to bone or distally along the shaft.

Fluoroscopy should be utilized to verify screw path placement during drilling of the most distal cluster of screws in the plate to prevent joint penetration.

Note: To reduce the risk of damage to the suture, the sutures should span between two holes and tie over a middle bridge.

Note: The EVOS[®] SMALL Preoperative Templates are available to assist with preoperative radiographic planning. Please reference catalog information for item number.



2.7/3.5mm Superior Distal Clavicle Plate

The plate lies along the superior aspect of the clavicle with the 2.7mm screw section covering the distal edge.



Plate placement should be adjusted to the best fit position on each individual patient. Fluoroscopy can be utilized to confirm plate position. Provisionally fix the plate to bone using K-wires, reduction clamps and/or provisional fixation pins and proceed with screw insertion as desired.

Fluoroscopy should be utilized to verify screw path placement during drilling.

Note: The EVOS[®] SMALL Preoperative Templates are available to assist with preoperative radiographic planning. Please reference catalog information for item number.

3.5mm Superior Medial Clavicle Plate

The plate lies along the superior aspect of the clavicle providing coverage of the medial 2/3 of the length of the bone.

Plate placement should be adjusted to the best fit position on each individual patient. Fluoroscopy can be utilized to confirm plate position.

Provisionally fix the plate to bone using K-wires, reduction clamps and/or provisional fixation pins and proceed with screw insertion as desired.

Fluoroscopy should be utilized to verify screw path placement during drilling.



Note: The EVOS[®] SMALL Preoperative Templates are available to assist with preoperative radiographic planning. Please reference catalog information for item number.

2.7mm Superior Medial Clavicle Plate

The plate lies along the superior aspect of the clavicle providing coverage of the medial 2/3 of the length of the bone.



It is to be used in smaller individuals or in conjunction with an anterior augmentation plate.

Plate placement should be adjusted to the best fit position on each individual patient. Fluoroscopy can be utilized to confirm plate position. Provisionally fix the plate to bone using K-wires, reduction clamps and/or provisional fixation pins and proceed with screw insertion as desired.

Fluoroscopy should be utilized to verify screw path placement during drilling.

Note: The EVOS[®] SMALL Preoperative Templates are available to assist with preoperative radiographic planning. Please reference catalog information for item number.



2.7/3.5mm Inferior Distal Clavicle Plate

The plate lies along the anterior-inferior aspect of the clavicle with the 2.7mm screw section within a few millimeters of the AC joint. The distal end of the plate has a slight inferior tilt to accommodate the distal clavicle and placing this section first makes application easier. The distal screws angle slightly superior to engage the full anterior to posterior width of the bone.

Plate placement should be adjusted to the best fit position on each individual patient. Fluoroscopy can be utilized to confirm plate position.

Provisionally fix the plate to bone using K-wires, reduction clamps and/or provisional fixation pins and proceed with screw insertion as desired.

Fluoroscopy should be utilized to verify screw path placement during drilling.



Note: The EVOS° SMALL Preoperative Templates are available to assist with preoperative radiographic planning. Please reference catalog information for item number.

2.7mm Inferior Distal Clavicle Plate

The plate lies along the anterior-inferior aspect of the clavicle within a few millimeters of the AC joint. The plate's distal end has a slight inferior tilt to accommodate the distal clavicle and placing this section first makes application easier.



Plate placement should be adjusted to the best fit position on each individual patient. Fluoroscopy can be utilized to confirm plate position. Provisionally fix the plate to bone using K-wires, Ball Spike Reduction Clamps and/or Provisional Fixation Pins and proceed with screw insertion as desired.

Fluoroscopy should be utilized to verify screw path placement during drilling.

Note: The EVOS[®] SMALL Preoperative Templates are available to assist with preoperative radiographic planning. Please reference catalog information for item number.



2.7/3.5mm Inferior Medial Clavicle Plate

The plate lies along the anterior inferior aspect of the clavicle providing coverage of the medial 3/4 of the length of the bone. More distal application may be possible if the plate is contoured.



Plate placement should be adjusted to the best fit position on each individual patient. Fluoroscopy can be utilized to confirm plate position.

Provisionally fix the plate to bone using K-wires, Ball Spike Reduction Clamps and/or Provisional Fixation Pins and proceed with screw insertion as desired.

Fluoroscopy should be utilized to verify screw path placement during drilling.

Note: The EVOS[®] SMALL Preoperative Templates are available to assist with preoperative radiographic planning. Please reference catalog information for item number.

3.5mm Superior Midshaft Plate

This Plate lies along the superior aspect of the clavicle providing coverage to the midshaft of the bone.

Plate placement should be adjusted to the best fit position on each individual patient. Fluoroscopy can be utilized to confirm plate position. Provisionally fix the plate to bone using K-wires, reduction clamps and/or provisional fixation pins and proceed with screw insertion as desired.

Fluoroscopy should be utilized to verify screw path placement during drilling.



Note: The EVOS[®] SMALL Preoperative Templates are available to assist with preoperative radiographic planning. Please reference catalog information for item number.



2.7mm Superior Midshaft Plate

This Plate lies along the superior aspect of the clavicle providing coverage to the midshaft of the bone.

Plate placement should be adjusted to the best fit position on each individual patient. Fluoroscopy can be utilized to confirm plate position.

Provisionally fix the plate to bone using K-wires, reduction clamps and/or provisional fixation pins and proceed with screw insertion as desired.

Fluoroscopy should be utilized to verify screw path placement during drilling.



Note: The EVOS[®] SMALL Preoperative Templates are available to assist with preoperative radiographic planning. Please reference catalog information for item number.

2.7mm Inferior Midshaft Plate

This plate lies along the anterior-inferior aspect of the clavicle covering the midshaft of the clavicle bone. Placing the distal end first may make application easier.



Plate placement should be adjusted to the best fit position on each individual patient. Fluoroscopy can be utilized to confirm plate position. Provisionally fix the plate to bone using K-wires, reduction clamps and/or provisional fixation pins and proceed with screw insertion as desired.

Fluoroscopy should be utilized to verify screw path placement during drilling.

Note: The EVOS[®] SMALL Preoperative Templates are available to assist with preoperative radiographic planning. Please reference catalog information for item number.

2.7/3.5mm Extra-Articular Volar Plate

Place the plate onto the volar side of the affected radius. Ensure the distal end of the plate does not go beyond the watershed line.

Plate placement should be adjusted to the best fit position on each individual patient. Fluoroscopy can be utilized to confirm plate position. Provisionally fix the plate to bone using K-wires, Ball Spike Reduction Clamps and/or Provisional Fixation Pins and proceed with screw insertion as desired.



Note: The EVOS[®] SMALL Preoperative Templates are available to assist with preoperative radiographic planning. Please reference catalog information for item number.



3.5mm Radial Shaft Plate

Place the plate onto the diaphysis of the radius with the middle of the plate over the fracture location to ensure adequate points of fixation on both sides of the fracture.

Plate placement and fluoroscopy should be utilized to verify screw path placement during drilling.



Note: The EVOS[®] SMALL Preoperative Templates are available to assist with preoperative radiographic planning. Please reference catalog information for item number.

2.7/3.5mm Proximal Radial Shaft Plate

Place the plate on the anterior side of the radius with the proximal 2.7mm screw cluster riding up the slope of the radial tuberosity.

Plate placement and fluoroscopy should be utilized to verify screw path placement during drilling.



Note: The EVOS[®] SMALL Preoperative Templates are available to assist with preoperative radiographic planning. Please reference catalog information for item number.

Screw Insertion

The choice of screws, and the order and configuration, is a decision to be made by the individual surgeon depending on the patient's circumstances and needs. Smith & Nephew does not recommend any particular screw insertion order or configuration of the various types of screws available within the EVOS[®] System.

Non-Locking screws for the EVOS System may be used outside the plate to assist with articular reduction or inter-fragmentary compression and through the plate to fix the plate to bone.

The 2.7mm Cortex Screws in the system may be used either through a 2.7mm plate screw hole or independently for fracture reduction.

Drill

- **Option 1: Independent of a plate:** Position the 2.0mm side of the 2.0mm x 2.7mm Drill Guide* to the bone and drill to the desired depth using the 2.0mm Short Drill Bit.
- **Option 2: Lag screw technique:** Position the 2.7mm side of the 2.0mm x 2.7mm Drill Guide* to the bone and drill through the near cortex using the 2.7mm Over-Drill to create a gliding hole for the 2.7mm screws. Insert the 2.0mm side of the 2.0mm x 2.7mm Drill Guide into the hole that was just drilled to ensure correct trajectory of the pilot-hole. Drill to the desired depth using the 2.0mm Short Drill Bit.



*Optional instrumentation available for this step. Please reference the Optional Instrumentation section.

• **Option 3: Through a plate (Neutral Mode):**

- **Fixed-angle threaded holes:** Thread in the 2.0mm Locking Drill Guide* into the desired screw hole and drill to the desired depth using the 2.0mm Long Drill Bit.
- **Non-threaded holes:** Position the neutral side of the 2.0mm Neutral/Compression Drill Guide* into the hole and drill to the desired depth using the 2.0mm Short Drill Bit.
- **Variable-Angle Holes:** The 2.0mm Variable-Angle/Fixed-Angle Drill Guide* is double sided. The conical shaped side (Variable-Angle) should be used if one intends to place the screw off-axis through the plate. The cylindrical shaped side (Fixed-Angle) should be used if one intends to place the screw to the nominal trajectory of the variable-angle hole. Determine the appropriate side of the Variable-Angle/Fixed-Angle Drill Guide and insert it into the desired plate hole. Ensure that the tip of the drill guide engages with the star shaped hole. Drill to the desired depth using the 2.0mm Short Drill Bit.



2.0mm Locking Drill Guide

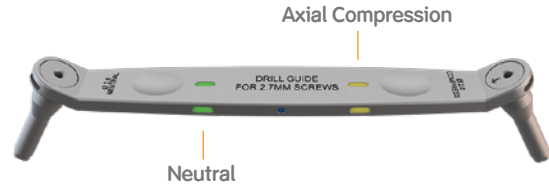

2.0mm Neutral/Compression Drill Guide
*Non-Locking Compression Plates only



2.0mm Variable-Angle/Fixed-Angle Drill Guide

*Optional instrumentation available for this step. Please reference the Optional Instrumentation section.

- **Option 4: Through a plate**
(Compression mode):

- **Non-threaded holes:** Position the compression side of the 2.0mm Neutral/Compression Drill Guide into the desired screw hole. To gain axial compression, position the drill guide so that the arrow on the drill guide is pointing towards the fracture. Drill to the desired depth using the 2.0mm Short Drill Bit.
- **Threaded holes:** Position the 2.0mm side of the 2.0mm x 2.7mm Drill Guide* into the desired screw hole. To gain axial compression, position the drill guide so that it is against the wall of the hole furthest from the fracture. Drill to the desired depth using the 2.0mm Short Drill Bit.



Arrow points toward the fracture

Countersink (optional)

If the screw is being used independently, countersinking the screw head may be desired to lower the screw head prominence on the bone. To countersink, attach the countersink for 2.7mm screws to the Small Bulb Handle with AO Quick Connect and prepare the bone surface by inserting the top into the predrilled hole and turning the countersink clockwise.

Measure

Measure for screw length by taking a direct reading from the 2.7mm Screw Depth Gauge.

Alternatively, 2.0mm short drill bits are calibrated and can be measured off of the back of the Fixed-Angle side of the 2.0mm VA Drill Guide, the 2.0mm Neutral/Compression Drill Guide and the 2.0mm side of the 2.0mm x 2.7mm Drill Guide. The 2.0mm long drill bit is calibrated to be measured off of the back of the 2.0mm Locking Drill Guide.

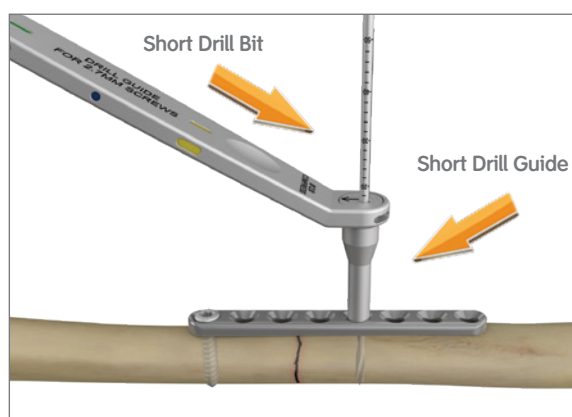

*Optional instrumentation available for this step. Please reference the Optional Instrumentation section.

Tap (optional)

The 2.7mm screws are self-tapping. However, in areas of dense cortical bone, tapping the bone may be desired prior to screw insertion. Tap by using the 2.7mm Tap. This should be performed manually by using the Small Bulb Handle with AO Quick Connect.

Screw Insertion

Insert the appropriate length 2.7mm Cortex Screw using the T8 Self-Retaining Screwdriver. Final tightening should be performed by hand with the T8 Fixed-Handle Driver.

Note: To prevent the AO Self-Retaining Driver from disengaging from the screw, axial pressure should be applied.

Driver options		
In set		
7117-5079	T8 Screwdriver Shaft Long	Self-Retaining
7117-5078	T8 Screwdriver Shaft Short	Self-Retaining
7117-5077	T8 Fixed-Handle Driver	Self-Retaining
Not in set		
7117-4986	T8 Linear Driver Shaft Short	Linear



The 2.7mm Locking Screws can be used in both threaded and variable-angle holes within 2.7mm plates. 2.7mm Locking Screws can be angled and locked up to 15° in any direction in 2.7mm variable-angle holes.

Note: It is not recommended to engage the variable-angle locking mechanism more than three times during screw insertion. Also, repeated use or damage to variable-angle locking tabs can cause:

- Screws to not lock to plate
- Screws to pass through plate

Drill

- **Through a plate:**
 - **For Fixed-Angle Threaded Holes:** Thread in the 2.0mm Locking Drill Guide* into the desired screw hole and drill to the desired depth using the 2.0mm Long Drill Bit.
 - **For Variable-Angle Holes:** The 2.0mm Variable-Angle/Fixed-Angle Drill Guide* is double sided. The conical shaped side (Variable-Angle) should be used if one intends to place the screw off-axis through the plate. The cylindrical shaped side (Fixed-Angle) should be used if one intends to place the screw to the nominal trajectory of the variable-angle hole. Determine the appropriate side of the Variable-Angle/Fixed-Angle Drill Guide and insert it into the desired plate hole. Ensure that the tip of the drill guide engages with the star shaped hole. Drill to the desired depth using the 2.0mm Short Drill Bit.



*Optional instrumentation available for this step. Please reference the Optional Instrumentation section.

Measure

Measure for screw length by taking a direct reading from the 2.7mm Screw Depth Gauge.

Note: When using a 2.7mm locking screw through a 2.7mm threaded hole, you must measure for the locking screw by taking a direct reading from the FOR Fixed-Angle LOCKING line on the 2.7mm Screw Depth Gauge (image shown to the right).

Alternatively, 2.0mm short drill bits are calibrated and can be measured off of the back of the Fixed-Angle side of the 2.0mm VA Drill Guide, the 2.0mm Neutral/Compression Drill Guide and the 2.0mm side of the 2.0mm/2.7mm Drill Guide. The 2.0mm long drill bit is calibrated to be measured off of the back of the 2.0mm Locking Drill Guide.

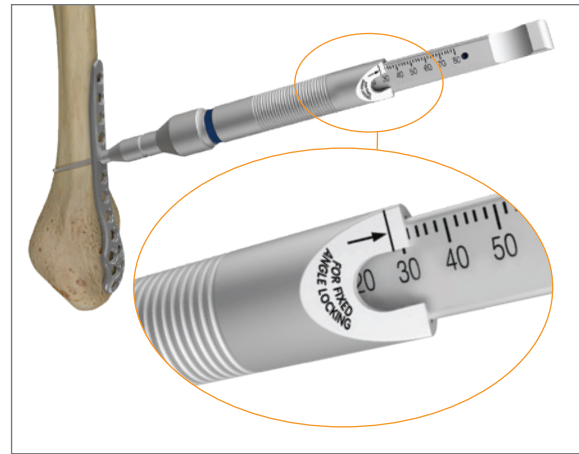

Tap (optional)

The 2.7mm screws are self-tapping. However, in areas of dense cortical bone, tapping the bone may be desired prior to screw insertion. Tap by using the 2.7mm Tap. This should be performed manually by using the Small Bulb Handle with AO Quick Connect.

Screw insertion

Insert the appropriate length 2.7mm Locking Screw using the T8 Self-Retaining Screwdriver. Final tightening should be performed by hand with the T8 Fixed-Handle Driver.

Note: To prevent the AO Self-Retaining Driver from disengaging from the screw, axial pressure should be applied.

Driver options		
In set		
7117-5079	T8 Screwdriver Shaft Long	Self-Retaining
7117-5078	T8 Screwdriver Shaft Short	Self-Retaining
7117-5077	T8 Fixed-Handle Driver	Self-Retaining
Not in set		
7117-4986	T8 Linear Driver Shaft Short	Linear

The 4.0mm Osteopenia Screws come in both fully threaded and partially threaded options. These screws are designed with an optimized thread form for use in areas of poor bone quality. Osteopenia Screws can be angled up to 10° off-axis in 2.7mm variable-angle holes.

Note: Osteopenia Screws can not be inserted off-axis in fixed-angle threaded holes.

Drill

- **Option 1: Independent of the plate:** Position the 2.0mm side of the 2.0mm x 2.7mm Drill Guide* to the bone and drill to the desired depth using the 2.0mm Short Drill Bit.



- **Option 2: Through a plate (Neutral Mode):**

- **Fixed-angle threaded holes:** Thread in the 2.0mm Locking Drill Guide* into the desired screw hole and drill to the desired depth using the 2.0mm Long Drill Bit.
- **Non-threaded holes:** Position the neutral side of the 2.0mm Neutral/Compression Drill Guide into the hole and drill to the desired depth using the 2.0mm Long Drill Bit.

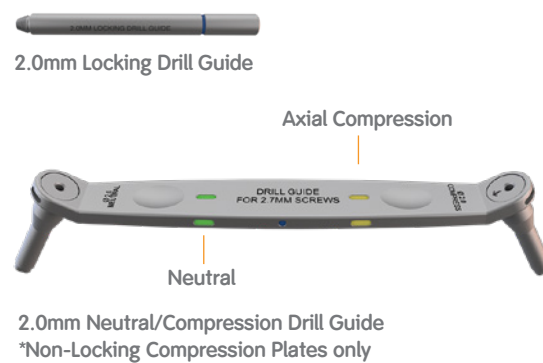

- **Variable-Angle Holes:** The 2.0mm Variable-Angle/Fixed-Angle Drill Guide is double sided. The conical shaped side (Variable-Angle) should be used if one intends to place the screw off-axis through the plate. The cylindrical shaped side (Fixed-Angle) should be used if one intends to place the screw to the nominal trajectory of the variable-angle hole. Determine the appropriate side of the Variable-Angle/Fixed-Angle Drill Guide and insert it into the desired plate hole. Ensure that the tip of the drill guide engages with the star shaped hole. Drill to the desired depth using the 2.0mm Long Drill Bit.



*Optional instrumentation available for this step. Please reference the Optional Instrumentation section.

Countersink (optional)

If the screw is being used independently, countersinking the screw head may be desired to lower the screw head prominence on the bone. To countersink, attach the countersink for 2.7mm screws to the Small Bulb Handle with AO Quick Connect and prepare the bone surface by inserting the top into the predrilled hole and turning the countersink clockwise.

Measure

Measure for screw length by using the 2.7mm Screw Depth Gauge.

Alternatively, 2.0mm short drill bits are calibrated and can be measured off of the back of the fixed-angle side of the 2.0mm VA Drill Guide, the 2.0mm Neutral/Compression Drill Guide and the 2.0mm side of the 2.0mm/2.7mm Drill Guide. The 2.0mm long drill bit is calibrated to be measured off of the back of the 2.0mm Locking Drill Guide.



Tap (optional)

The 4.0mm Osteopenia Screws are not self-tapping. In areas of dense cortical bone, tapping the bone may be desired prior to screw insertion. Tap by using the 4.0mm Tap. This should be performed manually by using the Small Bulb Handle with AO Quick Connect.

Screw Insertion

Insert the appropriate length 4.0mm Osteopenia Screw using the T8 Self-Retaining Screwdriver. Final tightening should be performed by hand with the T8 Fixed-Handle Driver.

Note: To prevent the AO Self-Retaining Driver from disengaging from the screw, axial pressure should be applied.

Driver options		
In set		
7117-5079	T8 Screwdriver Shaft Long	Self-Retaining
7117-5078	T8 Screwdriver Shaft Short	Self-Retaining
7117-5077	T8 Fixed-Handle Driver	Self-Retaining
Not in set		
7117-4986	T8 Linear Driver Shaft Short	Linear

The 3.5mm Cortex Screws may be used either through a 3.5mm plate or independently for fracture reduction.

Drill

- **Option 1: Independent of the plate:** Position the 2.5mm side of the 2.5mm x 3.5mm Drill Guide* to the bone and drill to the desired depth using the 2.5mm Short Drill Bit.

- **Option 2: Lag screw technique:** Position the 3.5mm side of the 2.5mm x 3.5mm Drill Guide* to the bone and drill through the near cortex using the 3.5mm Over-Drill to create a gliding hole for the 3.5mm screws. Insert the 2.5mm side of the 2.5mm x 3.5mm Drill Guide into the hole that was just drilled to ensure correct trajectory of the pilot-hole. Drill to the desired depth using the 2.5mm Short Drill Bit.

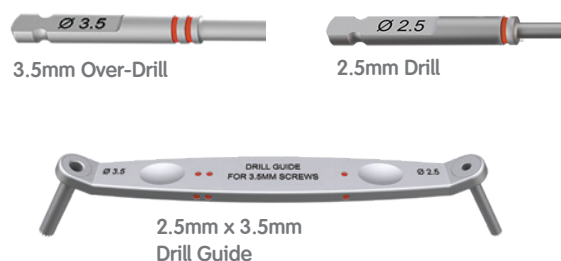

- **Option 3: Through a plate (Neutral Mode):**

- **Fixed-angle threaded holes:** Thread in the 2.5mm Locking Drill Guide* into the desired screw hole and drill to the desired depth using the 2.5mm Long Drill Bit.



- **Non-threaded holes:** Position the neutral side of the 2.5mm Neutral/Compression Drill Guide to the bone and drill to the desired depth using the 2.5mm Short Drill Bit.

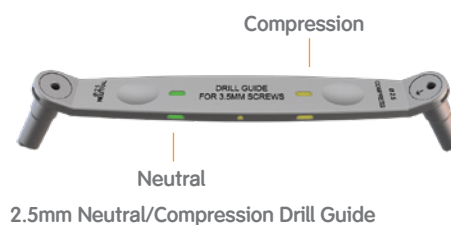

- **Variable-Angle Holes:** The 2.5mm Variable-Angle/Fixed-Angle Drill Guide* is double sided. The conical shaped side (Variable-Angle) should be used if one intends to place the screw off-axis through the plate. The cylindrical shaped sided (Fixed-Angle) should be used if one intends to place the screw to the nominal trajectory of the variable-angle hole. Determine the appropriate side of the Variable-Angle/Fixed-Angle Drill Guide and insert it into the desired screw hole. Ensure the tip of the drill guide engages with the star shaped hole. Drill to the desired depth using the 2.5mm Short Drill Bit.

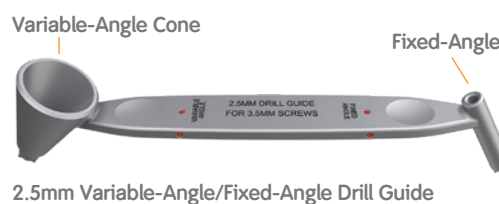

*Optional instrumentation available for this step. Please reference the Optional Instrumentation section.

- **Option 4: Through a plate (Compression Mode):**

- **Non-Threaded Holes:** For non-locking compression plates, position the compression side of the 2.5mm Neutral/Compression Drill Guide into the desired screw hole. To gain axial compression, position the drill guide so that the arrow on the drill guide is pointing towards the fracture. Drill to the desired depth using the 2.5mm Drill. For non-locking recon plates and 1/3 tubular plates, position the 2.5mm side of the 2.5mm x 3.5mm Drill Guide* into the desired screw hole. To gain axial compression, position the drill guide so that it is against the wall of the hole furthest from the fracture. Drill to the desired depth using the 2.5mm Short Drill Bit.

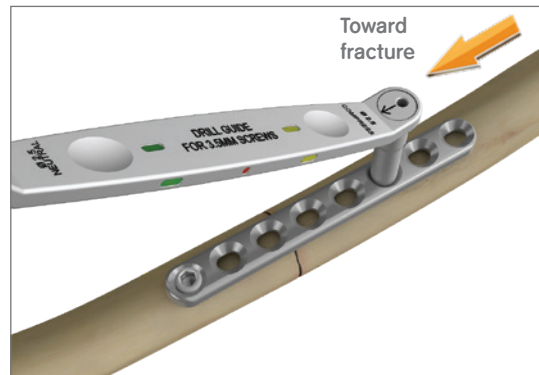

- **Threaded and Variable-Angle Holes:** Position the 2.5mm side of the 2.5mm x 3.5mm Drill Guide* into the desired screw hole. To gain axial compression, position the drill guide* so that it is against the wall of the hole furthest from the fracture. Drill to the desired depth using the 2.5mm Short Drill Bit.

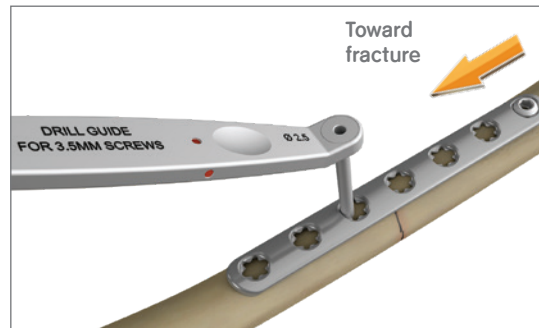

Countersink (optional)

If the screw is being used independently, countersinking the screw head may be desired to lower the screw head prominence on the bone. To countersink, attach the countersink for 3.5mm screws to the Small Bulb Handle with AO Quick Connect and prepare the bone surface by inserting the top into the predrilled hole and turning the countersink clockwise.

*Optional instrumentation available for this step. Please reference the Optional Instrumentation section.

Measure

Measure for screw length by using the 3.5mm Screw Depth Gauge.

Alternatively, 2.5mm short drill bits are calibrated and can be measured off of the back of the Fixed-Angle side of the 2.5mm VA Drill Guide, the 2.5mm Neutral/Compression Drill Guide and the 2.5mm side of the 2.5mm x 3.5mm Drill Guide.

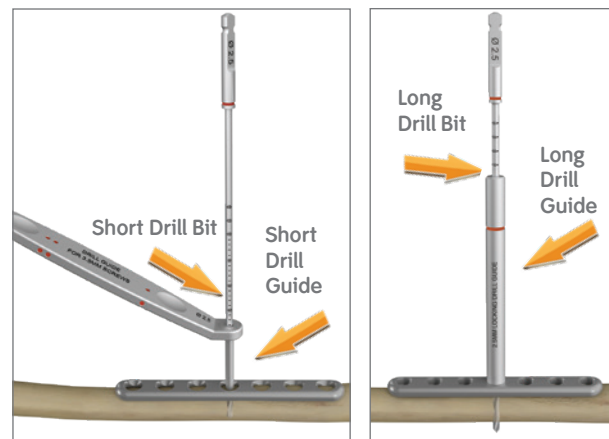

Tap (optional)

The 3.5mm screws are self-tapping. However, in areas of dense cortical bone, tapping the bone may be desired prior to screw insertion. Tap by using the 3.5mm Tap. This should be performed manually by using the Small Bulb Handle with AO Quick Connect.

Screw Insertion

Insert the appropriate length 3.5mm Cortex Screw using the 2.5mm Self-Retaining Screwdriver. Final tightening should be performed by hand using the 2.5mm Fixed-Handle Driver.

Note: To prevent the AO Self-Retaining Driver from disengaging from the screw, axial pressure should be applied.

The 2.5mm Long Drill Bit is calibrated to be measured off of the back of the 2.5mm Locking Drill Guide.



Driver options

In set

7117-5074	2.5mm Hex AO Driver – Short	Self-Retaining
7117-5073	2.5mm Hex AO Driver – Long	Self-Retaining
7117-5072	2.5mm Hex Fixed-Handle Driver	Linear
Not in set		
7117-0033	2.5mm Hex AO Driver – Short	Linear
7117-0169	2.5mm Hex AO Driver – Long	Linear

3.5mm Locking Screws can be angled and locked up to 15° in any direction in 3.5mm variable angle holes.

4.7mm Locking Osteopenia Screws can be angled and locked up to 10 degrees in any direction in 3.5mm variable angle holes.

Note: It is not recommended to engage the variable-angle locking mechanism more than three times during insertion.

Drill

- Through a plate:
 - **For Fixed-Angle Threaded Holes:** Thread in the 2.5mm Locking Drill Guide* into the desired screw hole and drill to the desired depth using the 2.5mm Long Drill Bit.
 - **For Variable-Angle Holes:** The 2.5mm Variable-Angle/Fixed-Angle Drill Guide* is double sided. The conical shaped side (Variable-Angle) should be used if one intends to place the screw off-axis through the plate. The cylindrical shaped side (Fixed-Angle) should be used if one intends to place the screw to the nominal trajectory of the variable-angle hole. Determine the appropriate side of the Variable-Angle/Fixed-Angle Drill Guide and insert it into the desired plate hole. Ensure that the tip of the drill guide engages with the star shaped hole. Drill to the desired depth using the 2.5mm Short Drill Bit.

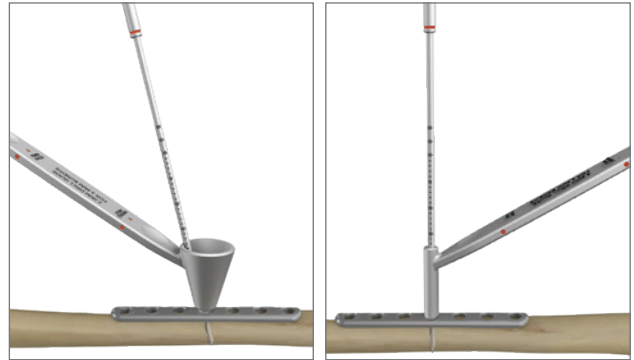

Measure

Measure for screw length by using the 3.5mm Screw Depth Gauge.

Alternatively, 2.5mm short drill bits are calibrated and can be measured off of the back of the Fixed-Angle side of the 2.5mm VA Drill Guide.

*Optional instrumentation available for this step. Please reference the Optional Instrumentation section.

Tap (optional)

The 3.5mm Locking Screws are self-tapping. However, in areas of dense cortical bone, tapping the bone may be desired prior to screw insertion. Tap by using the 3.5mm Tap. This should be performed manually by using the Small Bulb Handle with AO Quick Connect.

4.7mm Locking Osteopenia Screws can be angled and locked up to 10 degrees in any direction in 3.5mm variable angle holes.

The 4.7mm Locking Osteopenia Screws are not self-tapping. In areas of dense cortical bone, tapping the bone may be desired prior to screw insertion. Tap by using the 4.7mm Tap. This should be performed manually by using the Small Build Handle with AO Quick Connect.

Screw Insertion

Insert the appropriate length 3.5mm Locking Screw or 4.7mm Locking Osteopenia Screw using the 2.5mm Self-Retaining Screwdriver. Final tightening should be performed by hand using the 2.5mm Fixed-Handle Driver.*

Note: To prevent the AO Self-Retaining Driver from disengaging from the screw, axial pressure should be applied.

Driver options		
In set		
7117-5074	2.5mm Hex AO Driver - Short	Self-Retaining
7117-5073	2.5mm Hex AO Driver - Long	Self-Retaining
7117-5072	2.5mm Hex Fixed-Handle Driver	Linear
Not in set		
7117-0033	2.5mm Hex AO Driver - Short	Linear
7117-0169	2.5mm Hex AO Driver - Long	Linear

The 4.7mm Osteopenia Screws come in both fully threaded and partially threaded options. These screws are designed with an optimized thread form for use in areas of poor bone quality. Osteopenia Screws can be angled up to 10° off-axis in variable-angle holes.

Note: Osteopenia Screws can not be inserted off-axis in the fixed-angle threaded holes.

Drill

- **Option 1: Independent of the plate:** Position the 2.5mm side of the 2.5mm x 3.5mm Drill Guide* to the bone and drill to the desired depth using the 2.5mm Short Drill Bit.

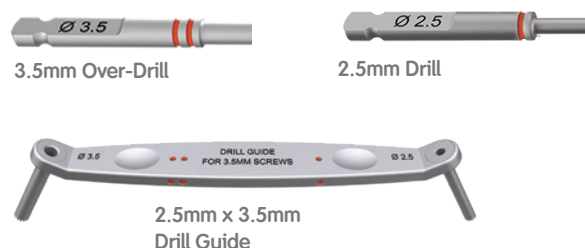

- **Option 2: Through a plate (Neutral Mode):**
 - **Fixed-angle threaded holes:** Thread in the 2.5mm Locking Drill Guide* into the desired screw hole and drill to the desired depth using the 2.5mm Long Drill Bit.
 - **Non-threaded holes:** Position the 2.5mm side of the 2.5mm x 3.5mm Drill Guide to the bone and drill to the desired depth using the 2.5mm Short Drill Bit.
 - **Variable-angle holes:** The 2.5mm Variable-Angle/Fixed-Angle Drill Guide* is double sided. The conical shaped side (Variable-Angle) should be used if one intends to place the screw off-axis through the plate. The cylindrical shaped side (Fixed-Angle) should be used if one intends to place the screw to the nominal trajectory of the variable-angle hole. Determine the appropriate side of the Variable-Angle/Fixed-Angle Drill Guide and insert it into the desired plate hole. Ensure that the tip of the drill guide engages with the star shaped hole. Drill to the desired depth using the 2.5mm Short Drill Bit.

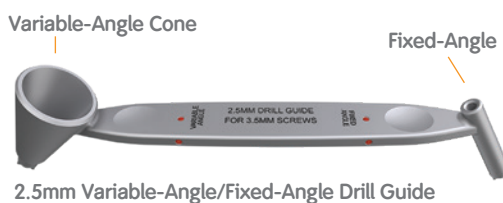

*Optional instrumentation available for this step. Please reference the Optional Instrumentation section.

Countersink (optional)

If the screw is being used independently, countersinking the screw head may be desired to lower the screw head prominence on the bone. To countersink, attach the countersink for 3.5mm screws to the Small Bulb Handle with AO Quick Connect and prepare the bone surface by inserting the top into the predrilled hole and turning the countersink clockwise.

Measure

Measure for screw length by using the 3.5mm Screw Depth Gauge.

Alternatively, 2.5mm short drill bits are calibrated and can be measured off of the back of the Fixed-Angle side of the 2.5mm VA Drill Guide. The 2.5mm long drill bit is calibrated to be measured off of the back of the 2.5mm Locking Drill Guide.

Tap (optional)

The 4.7mm Osteopenia Screws are not self-tapping. In areas of dense cortical bone, tapping the bone may be desired prior to screw insertion. Tap by using the 4.7mm Tap. This should be performed manually by using the Small Bulb Handle with AO Quick Connect.

Screw Insertion

Insert the appropriate length 4.7mm Osteopenia Screw using the 2.5mm Self-Retaining Screwdriver. Final tightening should be performed by hand using the 2.5mm Fixed-Handle Driver.

Note: To prevent the AO Self-Retaining Driver from disengaging from the screw, axial pressure should be applied.

Driver options

In set		
7117-5074	2.5mm Hex AO Driver - Short	Self-Retaining
7117-5073	2.5mm Hex AO Driver - Long	Self-Retaining
7117-5072	2.5mm Hex Fixed-Handle Driver	Linear
Not in set		
7117-0033	2.5mm Hex AO Driver - Short	Linear
7117-0169	2.5mm Hex AO Driver - Long	Linear

Snap In Drill Guides can be used in place of the double ended drill guides if preferred. Please see key below as to which techniques the guides can be substituted.

- Independent of a plate

2.7mm Cortex/4.0mm Osteopenia Screws:

- The 2.0mm Serrated Guide, Long, can be inserted into the modular handle to replace the 2.0mm x 2.7mm Drill Guide. Drill to the desired depth using the long 2.0mm Drill. Measurement may be taken off of the long 2.0mm Drill Bit or by using the 2.7mm Depth Gauge.



2.7mm Screws/4.0mm Osteopenia Screws

3.5mm Cortex/4.7mm Osteopenia Screws:

- The 2.5mm Serrated Guide, Long, can be inserted into the Modular Handle to replace the 2.5mm x 3.5mm Drill Guide. Drill to the desired depth using the long 2.5mm Drill. Measurement may be taken off of the long 2.5mm Drill Bit or by using the 3.5mm Depth Gauge.



3.5mm Screws/4.7mm Osteopenia Screws

• **Lag screw technique**

– **2.7mm Cortex/4.0mm Osteopenia Screws:**
The 2.0mm Serrated Guide, Long, and the 2.7mm Serrated Guide, Over-Drill, can be inserted into the Modular Handle to replace the 2.0mm x 2.7mm Drill Guide. Position the 2.7mm side of the Modular Handle to the bone and drill through the near cortex using the 2.7mm Over-Drill to create a gliding hole for the 2.7mm/4.0mm screws. Insert the 2.0mm side of the modular handle into the gliding hole to ensure correct trajectory of the pilot-hole. Drill to the desired depth using the 2.0mm Long Drill Bit. Measurement may be taken off of the long 2.0mm Drill Bit or by using the 2.7mm Depth Gauge.



2.7mm Screws / 4.0mm Osteopenia Screws

– **3.5mm Cortex/4.7mm Osteopenia Screws:**
The 2.5mm Serrated Guide, Long, and the 3.5mm Serrated Guide, Over-Drill, can be inserted into the Modular Handle to replace the 2.5mm x 3.5mm Drill Guide. Position the 3.5mm side of the Modular Handle to the bone and drill through the near cortex using the 3.5mm Over-Drill to create a gliding hole for the 3.5mm/4.7mm screws. Insert the 2.5mm side of the modular handle into the gliding hole to ensure correct trajectory of the pilot-hole. Drill to the desired depth using the 2.5mm Long Drill Bit. Measurement may be taken off of the long 2.0mm Drill Bit or by using the 3.5mm Depth Gauge.



3.5mm Screws / 4.7mm Osteopenia Screws

• **Through a plate (Neutral Mode):**

– **2.7mm Variable-Angle Holes:** The 2.0mm Guide, Long can be inserted into the Modular Handle to replace the 2.0mm Variable-Angle/Fixed-Angle Drill Guide. Drill to the desired depth using the long 2.0mm Drill. Measurement may be taken off of the long 2.0mm Drill Bit or by using the 2.7mm Depth Gauge.

2.7mm Screws:



– **3.5mm Variable-Angle Holes:** The 2.5mm Guide, Long can be inserted into the Modular Handle to replace the 2.5mm Variable-Angle/Fixed-Angle Drill Guide. Drill to the desired depth using the long 2.5mm Drill. Measurement may be taken off of the long 2.5mm Drill Bit or by using the 3.5mm Depth Gauge.

3.5mm Screws:



Locking screw guides can be used in place of the threaded drill guides if preferred. Please see key below as to which techniques the guides can be substituted for.

Through a Plate (Neutral Mode)

- 2.7mm Fixed-Angle Threaded Holes:** The 2.7mm Locking Screw Guide can be utilized by inserting the 2.0mm Drill Guide Insert into the 2.7mm Locking Screw Guide and threading the guide into the preferred 2.7mm threaded hole. Drill to the desired depth using the long 2.0mm Drill Bit. Measurement can be taken off of the long 2.0mm Drill Bit. To insert the screw, simply remove the drill guide insert and insert the appropriate length 2.7mm Locking Screw through the 2.7mm Locking Screw Guide using the T8 Driver to a depth where the top of the screw guide is between the two black lines on the T8 Driver shaft. Remove the 2.7mm Locking Screw Guide and proceed with final seating of the screw. Final seating should be performed manually using the T8 Fixed-Handle Driver.



2.7mm Locking Screw Guide with 2.0mm insert

- 3.5mm Fixed-Angle Threaded Holes:** The 3.5mm Locking Screw Guide can be utilized by inserting the 2.5mm Drill Guide Insert into the 3.5mm Locking Screw Guide and threading the guide into the preferred 3.5mm Threaded Hole. Drill to the desired depth using the long 2.5mm Drill Bit. Measurement can be taken off of the long 2.5mm Drill Bit. To insert the screw, simply remove the drill guide insert and insert the appropriate length 3.5mm Locking Screw through the 3.5mm Locking Screw Guide using the 2.5mm Hex Driver to a depth where the top of the screw guide is between the two black lines on the 2.5mm Hex Driver shaft. Remove the 3.5mm Locking Screw Guide and proceed with final seating of the screw. Final seating should be performed manually using the 2.5mm Fixed-Handle Driver.



Locking Screw Guide with Drill Bit

Note: In the event that a locking screw guide may be difficult to remove from the plate, the locking screw guide removal tool may be used.

Note: The 3.5mm Locking Screws Guide is for insertion of 3.5mm screws only. The 4.7mm Locking Osteopenia Screw cannot be inserted through the 3.5mm Locking Screw Guide.

3.5mm Locking Hole Inserts

3.5mm Locking Hole Inserts can be used in 3.5mm threaded holes in areas of potential peak stress.

Insert a 3.5mm Locking Hole Insert into an unused 3.5mm threaded hole using the 2.5mm Fixed-Handle Driver. The use of the locking hole insert is at the discretion of the surgeon.

Torque Limiter

The 1.7Nm Torque Limiting Screwdriver (7117-1238)* may be used to prevent over-insertion of the EVOS[®] SMALL 3.5mm locking screws and 3.5mm locking hole inserts.

Note: The 1.7Nm Torque Limiting Screwdriver should be calibrated every six months to ensure optimal instrument performance.

Stripped Hex Screw Removal

Attach the Screw Extractor (7117-1237)* to the Small Bulb Handle (7117-3543) and insert into the recess of the screw. Turn the extractor assembly counterclockwise to remove the screw. The Screw Extractor is compatible with all 3.5mm and 4.7mm EVOS[®] SMALL screws.

*Not included in set.

Obtain final AP and lateral radiographic images to confirm patient implant position and fracture reduction. Wound closure follows standard technique.

Cat. Item	Description	Qty
General Instrument Set – Set No 7141-0208		
7117-0220	EVOS [®] SMALL Frag Instrument Tray	1
7117-0221	EVOS SMALL Frag Instrument Tray Lid	1
7117-0250	EVOS 2.7mm Size Specific Instrumentation Tray	1
7117-0251	EVOS 3.5mm Size Specific Instrumentation Tray	1

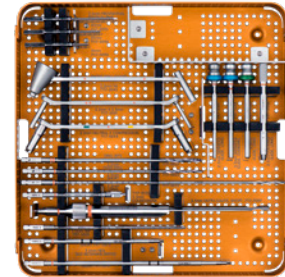
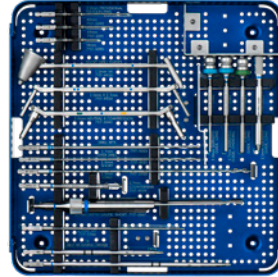
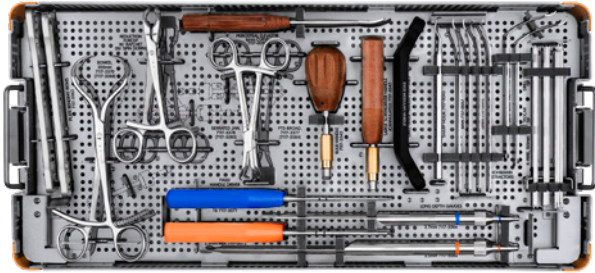

Cat. Item	Description	Qty
Instrument Set		
7117-0043	Sharp Hook	1
7117-0057	Hohmann Retractor 8mm	2
7117-0095	Hohmann Retractor 15mm	2
7117-0097	Periosteal Elevator - 6mm Curve	1
7117-3369	Hohmann Retractor - Bent 8mm Width	2
7117-3370	Reduction Forceps w/Ratchet, Bowed, 205mm	1
7117-3377	Reduction Forceps w/Pts-Broad	2
7117-3378	Reduction Forceps w/Serrated Jaw	2
7117-3543	Bulb Handle	1
7117-3547	Large Screwdriver Handle (Cannulated)	1
7117-4929	2.7mm Countersink w/AO QC	1
7117-4934	2.0mm x 2.7mm Drill Guide	1
7117-4935	2.0mm Fixed x 2.0mm VA Drill Guide	1
7117-5031	EVOS 3.5mm Countersink w/AO QC	1
7117-5040	EVOS 2.0mm Snap In Serrated Drill Guide	1
7117-5041	EVOS 2.5mm x 3.5mm Drill Guide	1
7117-5042	EVOS 2.5mm Fixed/VA Drill Guide	1
7117-5043	EVOS 2.0mm Compression/Neutral Drill Guide	1
7117-5044	EVOS 2.5mm Compression/Neutral Drill Guide	1
7117-5045	EVOS 2.0mm Snap In Drill Guide	1
7117-5047	EVOS 2.5mm Snap In Serrated Drill Guide	1
7117-5050	EVOS 2.5mm Snap In Drill Guide	1
7117-5051	EVOS 3.5mm Snap In Serrated Drill Guide	1
7117-5052	EVOS 2.0mm Locking Drill Guide	2
7117-5056	EVOS 2.5mm Locking Drill Guide	2
7117-5060	EVOS 2.7mm Snap In Serrated Drill Guide	1
7117-5063	EVOS SMALL Fragment Plate Bending Irons	2
7117-5065	EVOS Modular Handle	1
7117-5066	EVOS SMALL 2.7mm Depth Gauge, Long	1
7117-5067	EVOS SMALL 2.7mm Depth Gauge, Short	1
7117-5068	EVOS SMALL 3.5mm Depth Gauge, Long	1
7117-5069	EVOS SMALL 3.5mm Depth Gauge, Short	1
7117-5072	2.5mm Fixed-Handle Hex Driver	1
7117-5073	2.5mm Hex Driver Shaft Short	1
7117-5074	2.5mm Hex Driver Shaft Long	1
7117-5077	T8 Fixed-Handle Driver	1
7117-5078	T8 Screwdriver Shaft Short	1
7117-5079	T8 Screwdriver Shaft Long	1

Cat. Item	Description	Qty
Disposables – Set No 7141-0209		
7116-1012	1.25mm Trocar Tip K-Wire, 150mm	6
7116-1016	1.6mm Trocar Tip K-Wire, 150mm	6
7116-1020	2.0mm Trocar Tip K-Wire, 150mm	6
7117-3366	2.7mm Tap	1
7117-5020	2.0mm Drill w/AO QC, Long	2
7117-5021	2.0mm Drill w/AO QC, Short	2
7117-5022	2.5mm Drill w/AO QC, Long	2
7117-5023	2.5mm Drill w/AO QC, Short	2
7117-5024	2.7mm Over-Drill w/AO QC Long	1
7117-5025	2.7mm Over-Drill w/AO QC Short	1
7117-5027	3.5mm Over-Drill w/AO QC Short	1
7117-5028	3.5mm Tap w/AO QC	1
7117-5090	2.0mm Provisional Fixation Pin - 14mm	1
7117-5091	2.0mm Provisional Fixation Pin - 25mm	1
7117-5092	2.0mm Provisional Fixation Pin - 40mm	1
7117-5093	2.5mm Provisional Fixation Pin - 14mm	1
7117-5094	2.5mm Provisional Fixation Pin - 25mm	1
7117-5095	2.5mm Provisional Fixation Pin - 40mm	1

Cat. Item	Description	Qty
Implant Set – 7141-2027N		
7117-5064	Plate Bending Pliers	1
7117-5075	Recon Plate Bending Pliers	1
7117-0238	Straight Plate Tray	1
7117-0239	Straight Plate Tray Lid	1
7117-0222	Implant Tray	1
7117-0223	Implant Tray Lid	1
7117-0224	2.7/3.5mm Screw Caddy	1
7117-0225	2.7/3.5mm Screw Caddy Lid	1

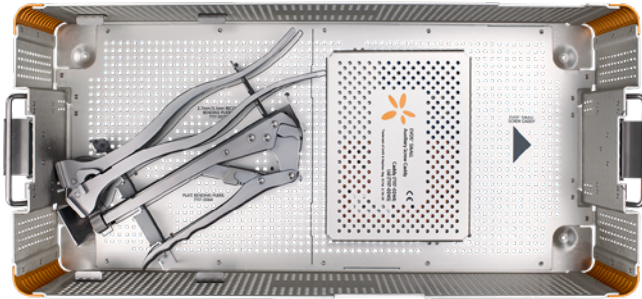

Cat. Item	Description	Qty
2.7mm Compression Plate		
7244-0404	4H, 33mm	1
7244-0406	6H, 50mm	1
7244-0408	8H, 67mm	1
7244-0410	10H, 84mm	1
7244-0415	15H, 127mm*	1
7244-0418	18H, 153mm*	0
2.7mm Locking Compression Plate		
7244-0204	4H, 31mm	1
7244-0206	6H, 46mm	1
7244-0208	8H, 61mm	1
7244-0210	10H, 76mm	1
7244-0215	15H, 113mm	1
7244-0218	18H, 136mm*	0
2.7mm Recon Plate		
7244-0304	4H, 33mm	1
7244-0306	6H, 49mm	1
7244-0308	8H, 65mm	1
7244-0310	10H, 81mm	1
7244-0315	15H, 121mm	0
7244-0318	18H, 145mm*	0
2.7mm Locking Recon Plate		
7244-0104	4H, 32mm	1
7244-0106	6H, 48mm	1
7244-0108	8H, 64mm	1
7244-0110	10H, 80mm	1
7244-0115	15H, 120mm*	0
7244-0118	18H, 144mm*	0

*Items available in sterile only

Cat. Item	Description	Qty
3.5mm Compression Plate		
7244-1004	4H, 52mm*	0
7244-1006	6H, 77mm	1
7244-1007	7H, 90mm	1
7244-1008	8H, 102mm	1
7244-1010	10H, 127mm	1
7244-1012	12H, 152mm	1
7244-1014	14H, 177mm	1
7244-1016	16H, 202mm*	0
7244-1018	18H, 227mm*	0
7244-1020	20H, 252mm*	0
3.5mm Locking Compression Plate		
7244-0704	4H, 47mm*	0
7244-0706	6H, 70mm	1
7244-0707	7H, 81mm	1
7244-0708	8H, 93mm	1
7244-0710	10H, 116mm	1
7244-0712	12H, 139mm	1
7244-0714	14H, 162mm	1
7244-0716	16H, 185mm*	0
7244-0718	18H, 208mm*	0
7244-0720	20H, 231mm*	0
3.5mm Recon Plate		
7244-0904	4H, 44mm	1
7244-0906	6H, 66mm	1
7244-0908	8H, 88mm	1
7244-0910	10H, 110mm	1
7244-0912	12H, 132mm*	0
7244-0914	14H, 154mm*	0
7244-0916	16H, 176mm*	0
7244-0918	18H, 198mm*	0
7244-0920	20H, 220mm*	0
7244-0922	22H, 242mm*	0
3.5mm Locking Recon Plate		
7244-0604	4H, 44mm*	0
7244-0606	6H, 66mm*	0
7244-0608	8H, 88mm*	0
7244-0610	10H, 110mm*	0
7244-0612	12H, 132mm*	0
7244-0614	14H, 154mm*	0
7244-0616	16H, 176mm*	0
7244-0618	18H, 198mm*	0
7244-0620	20H, 220mm*	0
7244-0622	22H, 242mm*	0
3.5mm 1/3rd Tubular Plate		
7244-0802	2H, 22mm*	0
7244-0804	4H, 46mm*	0
7244-0806	6H, 70mm	1
7244-0807	7H, 82mm	1
7244-0808	8H, 94mm	1
7244-0810	10H, 118mm	1
7244-0812	12H, 142mm*	0
3.5mm Locking 1/3rd Tubular Plate		
7244-0502	2H, 22mm*	0
7244-0504	4H, 46mm*	0
7244-0506	6H, 70mm	1
7244-0507	7H, 82mm	1
7244-0508	8H, 94mm	1
7244-0510	10H, 118mm	1
7244-0512	12H, 142mm*	0

*Items available in sterile only

Cat. Item	Description	Qty
2.7mm Cortex Screws		
7240-2706*	6mm*	0
7240-2707*	7mm*	0
7240-2708*	8mm*	0
7240-2709*	9mm*	0
7240-2710	10mm	4
7240-2711	11mm	4
7240-2712	12mm	4
7240-2713	13mm	4
7240-2714	14mm	4
7240-2715	15mm	4
7240-2716	16mm	4
7240-2717	17mm	4
7240-2718	18mm	4
7240-2719	19mm	4
7240-2720	20mm	4
7240-2722	22mm	4
7240-2724	24mm	4
7240-2726	26mm	4
7240-2728	28mm	4
7240-2730	30mm	4
7240-2732	32mm	4
7240-2734	34mm	4
7240-2736	36mm	4
7240-2738	38mm	4
7240-2740	40mm	4
7240-2742	42mm	4
7240-2744	44mm	4
7240-2746	46mm	4
7240-2748	48mm	4
7240-2750	50mm	2
7240-2755	55mm	2
7240-2760	60mm	2
7240-2765	65mm	2
7240-2770	70mm	2
7240-2775	75mm	2
7240-2780	80mm	2

Cat. Item	Description	Qty
2.7mm Locking Screws		
7241-2706*	6mm*	0
7241-2707*	7mm*	0
7241-2708*	8mm*	0
7241-2709*	9mm*	0
7241-2710	10mm	4
7241-2711	11mm	4
7241-2712	12mm	4
7241-2713	13mm	4
7241-2714	14mm	4
7241-2715	15mm	4
7241-2716	16mm	4
7241-2717	17mm	4
7241-2718	18mm	4
7241-2719	19mm	4
7241-2720	20mm	4
7241-2722	22mm	4
7241-2724	24mm	4
7241-2726	26mm	4
7241-2728	28mm	4
7241-2730	30mm	4
7241-2732	32mm	4
7241-2734	34mm	4
7241-2736	36mm	4
7241-2738	38mm	4
7241-2740	40mm	4
7241-2742	42mm	4
7241-2744	44mm	4
7241-2746	46mm	4
7241-2748	48mm	4
7241-2750	50mm	2
7241-2755	55mm	2
7241-2760	60mm	2
7241-2765	65mm	2
7241-2770	70mm	2
7241-2775	75mm	2
7241-2780	80mm	2

*Items available in sterile only

Cat. Item	Description	Qty
4.0mm Osteopenia Screws, Fully Threaded		
7242-4010	10mm	2
7242-4012	12mm	2
7242-4014	14mm	2
7242-4016	16mm	2
7242-4018	18mm	2
7242-4020	20mm	2
7242-4022	22mm	2
7242-4024	24mm	2
7242-4026	26mm	2
7242-4028	28mm	2
7242-4030	30mm	2
7242-4032	32mm	2
7242-4034	34mm	2
7242-4036	36mm	2
7242-4038	38mm	2
7242-4040	40mm	2
7242-4042	42mm	2
7242-4044	44mm	2
7242-4046	46mm	2
7242-4048	48mm	2
7242-4050	50mm	2
7242-4055	55mm	2
7242-4060	60mm	2
7242-4065	65mm	2
7242-4070	70mm	2
7242-4075	75mm	2
7242-4080	80mm	2

Cat. Item	Description	Qty
4.0mm Osteopenia Screws, Partially Threaded		
7243-4026	26mm	2
7243-4028	28mm	2
7243-4030	30mm	2
7243-4032	32mm	2
7243-4034	34mm	2
7243-4036	36mm	2
7243-4038	38mm	2
7243-4040	40mm	2
7243-4042	42mm	2
7243-4044	44mm	2
7243-4046	46mm	2
7243-4048	48mm	2
7243-4050	50mm	2
7243-4055	55mm	2
7243-4060	60mm	2
7243-4065	65mm	2
7243-4070	70mm	2
7243-4075	75mm	2
7243-4080	80mm	2

Cat. Item	Description	Qty
3.5mm Cortex Screws		
7240-3506*	6mm	0
7240-3508*	8mm	0
7240-3510	10mm	6
7240-3511	11mm	6
7240-3512	12mm	6
7240-3513	13mm	6
7240-3514	14mm	6
7240-3515	15mm	6
7240-3516	16mm	6
7240-3517	17mm	6
7240-3518	18mm	6
7240-3519	19mm	6
7240-3520	20mm	6
7240-3522	22mm	6
7240-3524	24mm	6
7240-3526	26mm	6
7240-3528	28mm	6
7240-3530	30mm	6
7240-3532	32mm	6
7240-3534	34mm	6
7240-3536	36mm	6
7240-3538	38mm	5
7240-3540	40mm	5
7240-3542	42mm	5
7240-3544	44mm	5
7240-3546	46mm	5
7240-3548	48mm	5
7240-3550	50mm	5
7240-3555	55mm	5
7240-3560	60mm	5
7240-3565	65mm	5
7240-3570	70mm	5
7240-3575	75mm	5
7240-3580	80mm	2
7240-3585	85mm	2
7240-3590	90mm	2
7240-3595*	95mm	0
7240-3600*	100mm	0
7240-3605*	105mm	0
7240-3610*	110mm	0

Cat. Item	Description	Qty
3.5mm Locking Screws		
7241-3508*	8mm	0
7241-3510	10mm	6
7241-3511	11mm	6
7241-3512	12mm	6
7241-3513	13mm	6
7241-3514	14mm	6
7241-3515	15mm	6
7241-3516	16mm	6
7241-3517	17mm	6
7241-3518	18mm	6
7241-3519	19mm	6
7241-3520	20mm	6
7241-3522	22mm	6
7241-3524	24mm	6
7241-3526	26mm	6
7241-3528	28mm	6
7241-3530	30mm	5
7241-3532	32mm	5
7241-3534	34mm	5
7241-3536	36mm	5
7241-3538	38mm	5
7241-3540	40mm	5
7241-3542	42mm	5
7241-3544	44mm	5
7241-3546	46mm	5
7241-3548	48mm	5
7241-3550	50mm	5
7241-3555	55mm	5
7241-3560	60mm	5
7241-3565	65mm	5
7241-3570	70mm	5
7241-3575	75mm	5
7241-3580	80mm	2
7241-3585	85mm	2
7241-3590	90mm	2
7241-3595*	95mm	0
7241-3600*	100mm	0
7241-3605*	105mm	0
7241-3610*	110mm	0

*Items available sterile only.

Cat. Item	Description	Qty
4.7mm Osteopenia Screws, Fully Threaded		
7242-4710	10mm	2
7242-4712	12mm	2
7242-4714	14mm	2
7242-4716	16mm	2
7242-4718	18mm	2
7242-4720	20mm	2
7242-4722	22mm	2
7242-4724	24mm	2
7242-4726	26mm	2
7242-4728	28mm	2
7242-4730	30mm	2
7242-4732	32mm	2
7242-4734	34mm	2
7242-4736	36mm	2
7242-4738	38mm	2
7242-4740	40mm	2
7242-4742	42mm	2
7242-4744	44mm	2
7242-4746	46mm	2
7242-4748	48mm	2
7242-4750	50mm	2
7242-4755	55mm	2
7242-4760	60mm	2
7242-4765	65mm	2
7242-4770	70mm	2
7242-4775	75mm	2
7242-4780	80mm	2
7242-4785	85mm	2
7242-4790	90mm	2
7242-4795*	95mm	0
7242-4800*	100mm	0
7242-4805*	105mm	0
7242-4810*	110mm	0
4.7mm Osteopenia Screws, Partially Threaded		
7243-4726	26mm	2
7243-4728	28mm	2
7243-4730	30mm	2
7243-4732	32mm	2
7243-4734	34mm	2
7243-4736	36mm	2
7243-4738	38mm	2
7243-4740	40mm	2
7243-4742	42mm	2
7243-4744	44mm	2
7243-4746	46mm	2
7243-4748	48mm	2
7243-4750	50mm	2
7243-4755	55mm	2
7243-4760	60mm	2
7243-4765	65mm	2
7243-4770	70mm	2
7243-4775	75mm	2
7243-4780	80mm	2
7243-4785	85mm	2
7243-4790	90mm	2
7243-4795*	95mm	0
7243-4800*	100mm	0
7243-4805*	105mm	0
7243-4810*	110mm	0

Cat. Item	Description	Qty
Washer		
7244-2127	Washer for 2.7mm Screws	6
7244-2227	Double Washer for 2.7mm Screws	3
7244-2135	Washer for 3.5mm Screws	6
7244-2235	Double Washer for 3.5mm Screws	3

*Items available sterile only.

Cat. Item	Description	Qty
Pilon Plate Tray – 7141-0218N		
7117-0230	Pilon Plate Tray	1
7117-0231	Pilon Plate Tray Lid	1

Left	Right	Description	Qty
2.7/3.5mm Medial Distal Tibia Plate			
7246-3909	7246-4009	9H, 130mm	1
7246-3912	7246-4012	12H, 162mm	1
7246-3915	7246-4015	15H, 195mm	1
7246-3918*	7246-4018*	18H, 228mm	0
7246-3921*	7246-4021*	21H, 261mm	0
2.7/3.5mm Anterolateral Distal Tibia Plate, Partial Articular			
7245-4306	7245-4406	6H, 87mm	1
7245-4309	7245-4409	9H, 120mm	1
2.7/3.5mm Anterolateral Distal Tibia Plate			
7246-4308	7246-4408	8H, 120mm	1
7246-4311	7246-4411	11H, 153mm	1
7246-4314	7246-4414	14H, 186mm	1
7246-4317*	7246-4417*	17H, 219mm	0
7246-4320*	7246-4420*	20H, 252mm	0
3.5mm Posterior Distal Tibia Plate			
7246-4506	7246-4606	6H, 98mm	1
7246-4509	7246-4609	9H, 131mm	1
7246-4512*	7246-4612*	12H, 163mm	0
7246-4515*	7246-4615*	15H, 196mm	0

Cat. Item	Description	Qty
2.7/3.5mm Anterior Distal Tibia Plate, Partial Articular		
7245-4103	3H, 74mm	1
7245-4106	6H, 107mm	1
7245-4109	9H, 140mm	1

*Items available in sterile only

Cat. Item	Description	Qty
Proximal Tibia Plate Tray – Set No 7141-0215N		
7117-0226	Proximal Tibia Plate Tray	2
7117-0227	Proximal Tibia Plate Tray Lid	1

Left	Right	Description	Qty
3.5mm Lateral Proximal Tibia, Partial Articular			
7245-3104	7245-3204	4H, 70mm	1
7245-3106	7245-3206	6H, 91mm	1
3.5mm Lateral Proximal Tibia			
7246-3104	7246-3204	4H, 70mm	1
7246-3106	7246-3206	6H, 91mm	1
7246-3108	7246-3208	8H, 113mm	1
7246-3110	7246-3210	10H, 134mm	1
7246-3113	7246-3213	13H, 167mm	1
7246-3116	7246-3216	16H, 200mm	1
7246-3118*	7246-3218*	18H, 221mm	0
7246-3120*	7246-3220*	20H, 243mm	0
7246-3122*	7246-3222*	22H, 265mm	0
7246-3124*	7246-3224*	24H, 287mm	0
3.5mm Posteromedial Proximal Tibia "T", Partial Articular			
7245-3304	7245-3404	4H, 71mm	1
7245-3307	7245-3407	7H, 103mm	1

Left	Right	Description	Qty
3.5mm Posteromedial Proximal Tibia "T"			
7246-3307	7246-3407	7H, 104mm	1
7246-3310*	7246-3410*	10H, 137mm	0
7246-3313*	7246-3413*	13H, 170mm	0
3.5mm Posteromedial Proximal Tibia "I", Partial Articular			
7245-3505	7245-3605	5H, 78mm	1
7245-3508	7245-3608	8H, 111mm	1

*Items available in sterile only

Cat. Item	Description	Qty
Medial Proximal Tibia Plate Tray – Set No 7141-0216N		
7117-0253	Medial Plate Tray	1
7117-0254	Medial Plate Tray Lid	1

Left	Right	Description	Qty
3.5mm Medial Proximal Tibia, Partial Articular			
7245-3704	7245-3804	4H, 75mm	1
7245-3708	7245-3808	8H, 117mm	1
3.5mm Medial Proximal Tibia			
7246-3708	7246-3808	8H, 117mm	1
7246-3710	7246-3810	10H, 138mm	1
7246-3713	7246-3813	13H, 170mm	1
7246-3716	7246-3816	16H, 201mm	1

*Items available in sterile only

Cat. Item	Description	Qty
Ankle Plate Tray – Set No 7141-0212N		
7117-0260	Ankle Plate Tray	1
7117-0261	Ankle Plate Tray Lid	1

Left	Right	Description	Qty
2.7mm Lateral Distal Fibula			
7246-4705	7246-4805	5H, 61mm	1
7246-4708	7246-4808	8H, 82mm	1
7246-4711*	7246-4811*	11H, 103mm	0
2.7/3.5mm Lateral Distal Fibula			
7246-5103	7246-5203	3H, 59mm	1
7246-5105	7246-5205	5H, 81mm	1
7246-5107	7246-5207	7H, 103mm	1
7246-5109	7246-5209	9H, 125mm	1
7246-5111	7246-5211	11H, 147mm	1
7246-5113*	7246-5213*	13H, 169mm	0
7246-5116*	7246-5216*	16H, 202mm	0
2.7/3.5mm Posterolateral Distal Fibula			
7246-5305	7246-5405	5H, 93mm	1
7246-5307	7246-5407	7H, 115mm	1
7246-5309	7246-5409	9H, 137mm	1
7246-5311	7246-5411	11H, 159mm	1
7246-5314*	7246-5414*	14H, 192mm	0
2.7/3.5mm Medial Distal Tibia, Partial Articular			
7245-3903	7245-4003	3H, 64mm	1
7245-3906	7245-4006	6H, 97mm	1
7245-3909	7245-4009	9H, 130mm	1

Left	Right	Description	Qty
3.5mm Posterior Distal Tibia, Partial Articular			
7245-4503	7245-4603	3H, 63mm	1
7245-4506	7245-4606	6H, 96mm	1
3.5mm Posterolateral Distal Fibula, Anti-Glide			
7245-5305	7245-5405	5H, 58mm	1
7245-5306	7245-5406	6H, 69mm	1
7245-5307	7245-5407	7H, 80mm	1
3.5mm Lateral Distal Fibula			
7246-4903	7246-5003	3H, 59mm	1
7246-4905	7246-5005	5H, 81mm	1
7246-4907	7246-5007	7H, 103mm	1
7246-4909	7246-5009	9H, 125mm	1
7246-4911	7246-5011	11H, 147mm	1
7246-4913*	7246-5013*	13H, 169mm	0
7246-4916*	7246-5016*	16H, 202mm	0

Left	Right	Description	Qty
3.5mm Medial Distal Femur Plate			
7257-3101	7257-3201	5H, 90mm	0
3.5mm Condylar Medial Distal Femur Plate			
7257-3102	7257-3202	5H, 115mm	0

*Items available in sterile only

Cat. Item	Description	Qty
Proximal Humerus Plate Tray – Set No 7141-0219N		
7117-0234	EVOS [®] SMALL Proximal Humerus Plate Tray	1
7117-0235	EVOS SMALL Proximal Humerus Plate Tray Lid	1

Cat. Item	Description	Qty
Greater Tuberosity		
7246-6705	5H 62mm	1
7246-6707	7H 84mm	1
Straight Proximal Humerus		
7246-6903	3H 92mm	1
7246-6905	5H 114mm	1
Curved Proximal Humerus		
Left	Right	
7246-7104	7246-7204	4h 92mm
7246-7106	7246-7206	6H 114mm
7246-7109	7246-7209	9H 147mm
7246-7112	7246-7212	12H 180mm
7246-7115	7246-7215	15H 213mm
7246-7118*	7246-7218*	18H 246mm
		1
		1
		1
		1
		1
		0

*Plates available sterile only

Cat. Item	Description	Qty
Elbow Plate Tray – 7141-0214N		
7117-0228	EVOS® SMALL Elbow Plate Tray	1
7117-0229	EVOS SMALL Elbow Plate Tray Lid	1

2.7/3.5mm Medial Distal Humerus

Left	Right		
7246-5503	7246-5603	3H 80mm	1
7246-5505	7246-5605	5H 102mm	1
7246-5507	7246-5607	7H 124mm	1
7246-5509	7246-5609	9H 146mm	1
7246-5512*	7246-5612*	12H 179mm	0

2.7/3.5mm Lateral Distal Humerus

Left	Right		
7246-5907	7246-6007	7H 90mm	1
7246-5909	7246-6009	9H 112mm	1
7246-5911	7246-6011	11H 134mm	1
7246-5913*	7246-6013*	13H 156mm	0

2.7/3.5mm Extended Medial Distal Humerus

Left	Right		
7246-5707*	7246-5807*	7H 130mm	0

2.7/3.5mm Posterolateral Distal Humerus

Left	Right		
7246-6106	7246-6206	6H 85mm	1
7246-6108	7246-6208	8H 107mm	1
7246-6110	7246-6210	10H 129mm	1
7246-6113	7246-6213	13H 162mm	1
7246-6117*	7246-6217*	17H 206mm	0

2.7/3.5mm Olecranon with Tines (Add-on set 7141-0273N)

Left	Right		
7246-6302	7246-6402	2H 61mm	1
7246-6304	7246-6404	4H 82mm	1
7246-6307	7246-6407	7H 114mm	1

2.7/3.5mm Extra-Articular Posterolateral Distal Humerus

Left	Right		
7246-9112	7246-9212	12H 151mm	1
7246-9116	7246-9216	16H 195mm	1
7246-9120	7246-9220	20H 239mm	1
7246-9125*	7246-9225*	25H 294mm	0

2.7/3.5mm Olecranon (Add-on set 7141-0274N)

Left	Right		
7246-6503*	7246-6603*	3H 61mm	1
7246-6505*	7246-6605*	5H 83mm	1
7246-6508*	7246-6608*	8H 114mm	1

Cat. Item	Description	Qty
Olecranon Plate Tray – 71410217N w/tines / 71410270N w/o tines**		
7117-0262	EVOS® SMALL Olecranon Plate Tray	1
7117-0263	EVOS SMALL Olecranon Plate Tray Lid	1

*Items available in sterile only

2.7/3.5mm Olecranon with Tines - 71410217N			
Left	Right		
7246-6302	7246-6402	2H 61mm	1
7246-6304	7246-6404	4H 82mm	1
7246-6307	7246-6407	7H 114mm	1
7246-6310	7246-6410	10H 147mm	1
7246-6313	7246-6413	13H 179mm	1

2.7/3.5mm Olecranon - 71410270N			
Left	Right		
7246-6503	7246-6603	3H 61mm	1
7246-6505	7246-6605	5H 83mm	1
7246-6508	7246-6608	8H 114mm	1
7246-6511	7246-6611	11H 147mm	1
7246-6514	7246-6614	14H 180mm	1

Cat. Item	Description	Qty
Clavicle Plate Tray - Set No. 7141-0213N		
7117-0280	EVOS SMALL Clavicle Plate Tray	1
7117-0281	EVOS SMALL Clavicle Plate Tray Lid	1
7117-0282	EVOS SMALL Superior Clavicle Plate Tray	1
7117-0283	EVOS SMALL Superior Clavicle Plate Tray Lid	1

Cat. Item	Description	Qty
2.7/3.5mm Superior Distal Clavicle		
Left	Right	
7246-7305	7246-7405	5H 89mm
7246-7307	7246-7407	7H 111mm
7246-7309	7246-7409	9H 133mm
7246-7311*	7246-7411*	11H 154mm
		0
3.5mm Superior Medial Clavicle		
	7246-7508	8H 87mm
	7246-7511*	11H 117mm
2.7mm Superior Medial Clavicle		
	7246-8910	10H 67mm
	7246-8913*	13H 87mm
	7246-8916	16H 105mm
3.5mm Superior Midshaft Clavicle		
7246-9508	7246-9608	8H 86mm
7246-9509*	7246-9609*	9H 97mm
7246-9510	7246-9610	10H 108mm
7246-9512	7246-9612	12H 130mm
2.7mm Superior Midshaft Clavicle		
7246-9714	7246-9814	14H 93mm
7246-9716*	7246-9816*	16H 107mm
7246-9718	7246-9818	18H 120mm
2.7/3.5mm Inferior Distal Clavicle		
7246-7703	7246-7803	3H 86mm
7246-7705	7246-7805	5H 107mm
7246-7707	7246-7807	7H 129mm
7246-7709*	7246-7809*	9H 151mm
		0
2.7mm Inferior Distal Clavicle		
7246-8703	7246-8803	3H 81mm
7246-8707	7246-8807	7H 116mm
7246-8713	7246-8813	13H 151mm
		0
2.7mm Inferior Midshaft Clavicle		
	7246-9908	8H 99mm
	7246-9911	11H 120mm
		1
2.7/3.5mm Inferior Medial Clavicle Plate		
	7246-7906	6H 86mm
	7246-7909*	9H 115mm
		0

*Items available sterile only

Cat. Item	Description	Qty
Forearm Plate Tray – 7141-0264N		
7117-0264	EVOS® SMALL FOREARM Plate Tray	1
7117-0265	EVOS SMALL FOREARM Plate Tray Lid	1

Cat. Item		Description	Qty
Left	Right		
7246-8110	7246-8210	EVOS Distal Radius Volar Plate 10H Standard 138mm	1
7246-9305	7246-9405	EVOS Proximal Radial Shaft Plate 5H 95mm	1
7246-9308	7246-9408	EVOS Proximal Radial Shaft Plate 8H 130mm	1

Cat. Item	Description	Qty
7246-8608	EVOS Radial Shaft Plate 8H 98mm	1
7246-8610	EVOS Radial Shaft Plate 10H 122mm	1
7246-8612	EVOS Radial Shaft Plate 12H 146mm	1
7246-8614	EVOS Radial Shaft Plate 14H 170mm	1
7246-8616	EVOS Radial Shaft Plate 16H 193mm	1

*Items available sterile only

Cat. Item	Description	Qty
Auxiliary Screw Tray – Set No 7141-0228N		
7117-0244	Aux Screw Tray	1
7117-0245	Aux Screw Lid	1

Cat. Item	Description	Qty
2.7mm Cortex Screws		
7240-2706	6mm	4
7240-2707	7mm	4
7240-2708	8mm	4
7240-2709	9mm	4
7240-2710	10mm	4
7240-2711	11mm	4
7240-2712	12mm	4
7240-2713	13mm	4
7240-2714	14mm	4
7240-2715	15mm	4
7240-2716	16mm	4
2.7mm Locking Screws		
7241-2706	6mm	4
7241-2707	7mm	4
7241-2708	8mm	4
7241-2709	9mm	4
7241-2710	10mm	4
7241-2711	11mm	4
7241-2712	12mm	4
7241-2713	13mm	4
7241-2714	14mm	4
7241-2715	15mm	4
7241-2716	16mm	4
3.5mm Cortex Screws		
7240-3506	6mm	4
7240-3508	8mm	4
7240-3510	10mm	6
7240-3511	11mm	6
7240-3512	12mm	6
7240-3513	13mm	6
7240-3514	14mm	6
7240-3515	15mm	6
7240-3516	16mm	6
7240-3517	17mm	6
7240-3518	18mm	4
7240-3519	19mm	4
7240-3520	20mm	4
7240-3522	22mm	4

Cat. Item	Description	Qty
4.7mm Locking Osteopenia Screws, Fully Threaded		
7241-4710*	10mm	0
7241-4712*	12mm	0
7241-4714*	14mm	0
7241-4716*	16mm	0
7241-4718*	18mm	0
7241-4720*	20mm	0
7241-4722*	22mm	0
7241-4724*	24mm	0
7241-4726*	26mm	0
7241-4728*	28mm	0
7241-4730*	30mm	0
7241-4732*	32mm	0
7241-4734*	34mm	0
7241-4736*	36mm	0
7241-4738*	38mm	0
7241-4740*	40mm	0
7241-4742*	42mm	0
7241-4744*	44mm	0
7241-4746*	46mm	0
7241-4748*	48mm	0
7241-4750*	50mm	0
7241-4755*	55mm	0
7241-4760*	60mm	0
7241-4765*	65mm	0
7241-4770*	70mm	0
7241-4775*	75mm	0
7241-4780*	80mm	0
4.7mm Osteopenia Screws, Fully Threaded		
7242-4710	10mm	2
7242-4712	12mm	2
7242-4714	14mm	2
7242-4716	16mm	2
3.5mm Locking Hole Inserts		
7241-3500	Locking Hole Insert	4
4.0mm Fully Threaded Osteopenia Screws		
7242-4010	10mm	2
7242-4012	12mm	2
7242-4014	14mm	2
7242-4016	16mm	2

Cat. Item	Description	Qty
Spin-Down Forceps – Set No 7141-0222		
7117-5084	Reduction Forceps with Points, Broad, Spin-down	2
7117-5085	Reduction Forceps, Serrated Jaw, Spin-down	2
7117-5088	Reduction Forceps, Bowed, 205mm, Spin-down	1
Linear driver and over-capture – Set No 7141-0220		
7117-4986	T8 Linear Driver Shaft	1
7117-4989	T8 Holding Sleeve	1
7117-5098	2.5mm Linear Driver Shaft	1
7117-6002	2.5mm Holding Sleeve 2cm	1
7117-4998	T8 Linear Driver/ Over-capture Bracket	1
7117-6004	2.5mm Linear Driver/ Over-capture Bracket	1
Locking Screw Guide – Set No 7141-0221		
7117-5048	2.7mm Locking Screw Guide	1
7117-5049	2.0mm Drill Guide Insert	1
7117-5057	3.5mm Locking Screw Guide	1
7117-5058	2.5mm Drill Guide Insert	1
7117-5097	Screw Guide Removal Tool	1
7117-4996	2.7mm Locking Screw Guide Bracket	1
7117-4997	3.5mm Locking Screw Guide Bracket	1
Optional Disposables		
7110-1413	1.25mm Drill Tip K-Wire, 150mm	6
7110-1501	1.6mm Drill Tip K-Wire, 150mm	6
7110-1502	2.0mm Drill Tip K-Wire, 150mm	6

Cat. Item	Description	Qty
Optional Linear driver and over-capture		
7117-6007	2.5mm Hex Linear Driver Shaft - Long	1
7117-6003	2.5mm Hex Holding Sleeve, 8cm	1

Cat. Item	Description	Qty
EVOS® LITE Trays, Caddies, and Lids		
7117-0288	EVOS LITE Instrument & Implant Tray Instrument	1
7117-0289	EVOS LITE Instrument & Implant Tray Lid	1
7117-0292	EVOS LITE Straight Plate Caddy	1
7117-0293	EVOS LITE Straight Plate Caddy Lid	1
7117-0258	EVOS LITE 2.7mm Screw Caddy	1
7117-0259	EVOS LITE 2.7mm Screw Caddy Lid	1
7117-0284	EVOS LITE 2.7mm Module	1
7117-0285	EVOS LITE 3.5mm Module	1
7117-0290	EVOS LITE 3.5mm Screw Caddy	1
7117-0291	EVOS LITE 3.5mm Screw Caddy Lid	1
7117-0294	EVOS LITE General Instrument Insert	1
7117-0256	EVOS LITE INSTRUMENT TRAY	1
7117-0257	EVOS LITE INSTRUMENT TRAY LID	1
7117-0286	EVOS LITE MODULE LID	2

Cat. Item	Description
EVOS® LITE Set BOMs	
7141-0278N	EVOS LITE Instrument & Implant Set
7141-0279	EVOS LITE Instrument Set
7141-0287	EVOS LITE Module Set
7141-0280	EVOS LITE Screw Set - Sterile

*Items available sterile only

Cat. Item	Description
EVOS® SMALL ANKLE Template Set – Set No 7141-0235	
7612-4009	EVOS 2.7mm/3.5mm Partial Articular Medial Distal Tibia Template 9H R 129mm
7612-3909	EVOS 2.7mm/3.5mm Partial Articular Medial Distal Tibia Template 9H L 129mm
7612-4506	EVOS 3.5mm Partial Articular Posterior Distal Tibia Template 6H L 96mm
7612-4606	EVOS 3.5mm Partial Articular Posterior Distal Tibia Template 6H R 96mm
7611-4711	EVOS 2.7mm Lateral Distal Fibula Template 11H L 103mm
7611-4811	EVOS 2.7mm Lateral Distal Fibula Template 11H R 103mm
7611-4916	EVOS 3.5mm Lateral Distal Fibula Template 16H L 202mm
7611-5016	EVOS 3.5mm Lateral Distal Fibula Template 16H R 202mm
7611-5216	EVOS 2.7/3.5mm Lateral Distal Fibula Template 16H R 202mm
7611-5314	EVOS 2.7mm/3.5mm Posterolateral Distal Fibula Template 14H L 192mm
7611-5116	EVOS 2.7/3.5mm Lateral Distal Fibula Template 16H L 202mm
7611-5414	EVOS 2.7/3.5mm Posterolateral Distal Fibula Template 14H R 192mm
7611-5007	EVOS 3.5mm Lateral Distal Fibula Template 7H R 103mm
7611-5107	EVOS 2.7/3.5mm Lateral Distal Fibula Template 7H L 103mm
7611-4907	EVOS 3.5mm Lateral Distal Fibula Template 7H L 103mm
7611-5207	EVOS 2.7/3.5mm Lateral Distal Fibula Template 7H R 103mm
7611-5309	EVOS 2.7mm/3.5mm Posterolateral Distal Fibula Template 9H L 137mm
7611-5409	EVOS 2.7mm/3.5mm Posterolateral Distal Fibula Template 9H R 137mm
7611-5307	EVOS Posterolateral Distal Fibula Anit-GliDE Template 7H L 80mm
7612-5407	EVOS Posterolateral Distal Fibula Anit-GliDE Template 7H R 80mm
7117-0272	EVOS SMALL ANKLE Template Tray
7117-0273	EVOS SMALL ANKLE Template Tray Lid

Cat. Item	Description
EVOS® SMALL PROXIMAL TIBIA Template SET - Set No. 7141-0236	
7611-3113	EVOS 3.5mm Lateral Proximal Tibia Template 13H L 165mm
7611-3213	EVOS 3.5mm Lateral Proximal Tibia Template 13H R 165mm
7611-3224	EVOS 3.5mm Lateral Proximal Tibia Template 24H R 285mm
7611-3124	EVOS 3.5mm Lateral Proximal Tibia Template 24H L 285mm
7611-3413	EVOS 3.5mm Posteromedial Proximal Tibia T Template 13H R 170mm
7611-3716	EVOS 3.5mm Medial Proximal Tibia Template 16H L 204mm
7611-3313	EVOS 3.5mm Posteromedial Proximal Tibia T Template 13H L 170mm
7611-3816	EVOS 3.5mm Medial Proximal Tibia Template 16H R 204mm
7612-3106	EVOS 3.5mm Partial Articular Lateral Proximal Tibia Template 6H L 91mm
7612-3206	EVOS 3.5mm Partial Articular Lateral Proximal Tibia Template 6H R 91mm
7612-3407	EVOS 3.5mm Partial Articular Posteromedial Proximal Tibia T Template 7H R 103mm
7612-3508	EVOS 3.5mm Partial Articular Posteromedial Proximal Tibia I Template 8H L 110mm
7612-3307	EVOS 3.5mm Partial Articular Posteromedial Proximal Tibia T Template 7H L 103mm
7612-3708	EVOS 3.5mm Partial Articular Medial Proximal Tibia Template 8H L 118mm
7612-3808	EVOS 3.5mm Partial Articular Medial Proximal Tibia Template 8H R 118mm
7612-3608	EVOS 3.5mm Partial Articular Posteromedial Proximal Tibia I Template 8H R 110mm
7117-0269	EVOS SMALL Proximal Tibia Template Tray Lid
7117-0268	EVOS SMALL Proximal Tibia Template Tray

Cat. Item	Description
EVOS° SMALL PILON Template SET - Set No. 7141-0281	
7611-3912	EVOS 2.7mm/3.5mm Medial Distal Tibia Template 12H L 161mm
7611-4012	EVOS 2.7mm/3.5mm Medial Distal Tibia Template 12H R 161mm
7611-4021	EVOS 2.7mm/3.5mm Medial Distal Tibia Template 21H R 260mm
7611-3921	EVOS 2.7mm/3.5mm Medial Distal Tibia Template 21H L 260mm
7611-4320	EVOS 2.7mm/3.5mm Anterolateral Distal Tibia Template 20H L 252mm
7611-4414	EVOS 2.7mm/3.5mm Anterolateral Distal Tibia Template 14H R 186mm
7611-4314	EVOS 2.7mm/3.5mm Anterolateral Distal Tibia Template 14H L 186mm
7611-4420	EVOS 2.7mm/3.5mm Anterolateral Distal Tibia Template 20H R 252mm
7611-4509	EVOS 3.5mm Posterior Distal Tibia Template 9H L 128mm
7611-4515	EVOS 3.5mm Posterior Distal Tibia Template 15H L 194mm
7611-4615	EVOS 3.5mm Posterior Distal Tibia Template 15H R 194mm
7612-4109	EVOS 2.7mm/3.5mm Partial Articular ANTERIOR Distal Tibia Template 9H 140mm
7611-4609	EVOS 3.5mm Posterior Distal Tibia Template 9H R 128mm
7612-4409	EVOS 2.7mm/3.5mm Partial Articular Anterolateral Distal Tibia Template 9HR120mm
7612-4309	EVOS 2.7mm/3.5mm Partial Articular Anterolateral Distal Tibia Template 9H L120mm
7117-0270	EVOS SMALL PILON Template Tray
7117-0271	EVOS SMALL PILON Template Tray Lid

Cat. Item	Description
EVOS° SMALL ELBOW Template SET - Set No. 7141-0284	
7611-5507	EVOS 2.7/3.5mm Medial Distal Humerus Template 7H L 124mm
7611-5607	EVOS 2.7/3.5mm Medial Distal Humerus Template 7H R 124mm
7611-5612	EVOS 2.7mm/3.5mm Medial Distal Humerus Template 12H R 179mm
7611-5512	EVOS 2.7mm/3.5mm Medial Distal Humerus Template 12H L 179mm
7611-5707	EVOS 2.7mm/3.5mm Extended Medial Distal Humerus Template 7H L 130mm
7611-5807	EVOS 2.7mm/3.5mm Extended Medial Distal Humerus Template 7H R 130mm
7611-5909	EVOS 2.7mm/3.5mm Lateral Distal Humerus Template 9H L 112mm
7611-6009	EVOS 2.7mm/3.5mm Lateral Distal Humerus Template 9H R 112mm
7611-6013	EVOS 2.7mm/3.5mm Lateral Distal Humerus Template 13H R 156mm
7611-5913	EVOS 2.7mm/3.5mm Lateral Distal Humerus Template 13H L 156mm
7611-6110	EVOS 2.7mm/3.5mm Posterolateral Distal Humerus Template 10H L 129mm
7611-6117	EVOS 2.7mm/3.5mm Posterolateral Distal Humerus Template 17H L 206mm
7611-6210	EVOS 2.7mm/3.5mm Posterolateral Distal Humerus Template 10H R 129mm
7611-9116	EVOS 2.7mm/3.5mm Extra-Articular Distal Humerus Template 16H L 195mm
7611-9125	EVOS 2.7mm/3.5mm Extra-Articular Distal Humerus Template 25H L 294mm
7611-9216	EVOS 2.7mm/3.5mm Extra-Articular Distal Humerus Template 16H R 195mm
7611-6217	EVOS 2.7mm/3.5mm Posterolateral Distal Humerus Template 17H R 206mm
7611-9225	EVOS 2.7mm/3.5mm Extra-Articular Distal Humerus Template 25H R 294mm
7117-0295	EVOS SMALL Distal Humerus Template Tray
7117-0296	EVOS SMALL Distal Humerus Template Tray Lid

Cat. Item	Description
EVOS° SMALL Straight plate Template SET - Set No 7141-0234	
7611-0218	EVOS 2.7mm Locking Compression Template 18H 136mm
7611-0210	EVOS 2.7mm Locking Compression Template 10H 76mm
7611-0418	EVOS 2.7mm Compression Template 18H 153mm
7611-0410	EVOS 2.7mm Compression Template 10H 84mm
7611-0512	EVOS 3.5mm 1/3 Tubular Template FOR Locking and Non-Locking plates 12H 142mm
7611-0720	EVOS 3.5mm Locking Compression Template 20H 231mm
7611-0710	EVOS 3.5mm Locking Compression Template 10H 116mm
7611-1010	EVOS 3.5mm Compression Template 10H 127mm
7611-1020	EVOS 3.5mm Compression Template 20H 252mm
7611-0204	EVOS 2.7mm Recon Template FOR Locking and Non-Locking plates 10H 80mm
7611-0508	EVOS 3.5mm 1/3 Tubular Template FOR Locking and Non-Locking plates 8H 94mm
7611-0118	EVOS 2.7mm Recon Template FOR Locking and Non-Locking plates 18H 144mm
7611-0622	EVOS 3.5mm Recon Template FOR Locking and Non-Locking plates 22H 242mm
7611-0610	EVOS 3.5mm Recon Template FOR Locking and Non-Locking plates 10H 110mm
7611-0274	EVOS SMALL Straight plate Template plate Tray
7611-0275	EVOS SMALL Straight plate Template plate Tray Lid

Cat. Item	Description
EVOS° SMALL Humerus Template SET - Set No7141-0283	
7611-6707	EVOS Greater Tuberosity Template 7H 84mm
7611-7109	EVOS 3.5mm Curved Proximal Humerus Template 9H L 147mm
7611-7118	EVOS 3.5mm Curved Proximal Humerus Template 18H L 246mm
7611-6905	EVOS 3.5mm Straight Proximal Humerus Template 5H 114mm
7611-7218	EVOS 3.5mm Curved Proximal Humerus Template 18H R 246mm
7611-7209	EVOS 3.5mm Curved Proximal Humerus Template 9H R 147mm
7611-0300	EVOS SMALL Proximal Humerus Template Tray Lid
7611-0299	EVOS SMALL Proximal Humerus Template Tray

Cat. Item	Description
EVOS° SMALL OLECRANON Template SET - Set No. 7141-0285	
7611-6313	EVOS 2.7mm/3.5mm Olecranon Template WITH TINES 13H L 179mm
7611-6307	EVOS 2.7mm/3.5mm Olecranon Template WITH TINES 7H L 114mm
7611-6413	EVOS 2.7mm/3.5mm Olecranon Template WITH TINES 13H R 179mm
7611-6508	EVOS 2.7mm/3.5mm Olecranon Template 8H L 114mm
7611-6407	EVOS 2.7mm/3.5mm Olecranon Template WITH TINES 7H R 114mm
7611-6514	EVOS 2.7mm/3.5mm Olecranon Template 14H L 180mm
7611-6608	EVOS 2.7mm/3.5mm Olecranon Template 8H R 114mm
7611-6614	EVOS 2.7mm/3.5mm Olecranon Template 14H R 180mm
7611-0298	EVOS SMALL Olecranon Template Tray Lid
7611-0297	EVOS SMALL Olecranon Template Tray

Cat. Item	Description
EVOS° SMALL CLAVICLE Template SET - Set No. 7141-0282	
7611-7411	EVOS 2.7mm/3.5mm Superior Distal Clavicle Template 11H R 154mm
7611-7709	EVOS 2.7mm/3.5mm Inferior Distal Clavicle Template 9H L 151mm
7611-7311	EVOS 2.7mm/3.5mm Superior Distal Clavicle Template 11H L 154mm
7611-7909	EVOS 2.7mm/3.5mm Inferior Medial Clavicle Template 9H 115mm
7611-8913	EVOS 2.7mm Inferior Distal Clavicle Template 13H L 151mm
7611-7809	EVOS 2.7mm/3.5mm Inferior Distal Clavicle Template 9H R 151mm
7611-9013	EVOS 2.7mm Inferior Distal Clavicle Template 13H R 151mm
7611-9512	EVOS 3.5mm Superior Midshaft Clavicle Template 12H L 130mm
7611-9612	EVOS 3.5mm Superior Midshaft Clavicle Template 12H R 130mm
7611-9818	EVOS 2.7mm Superior Midshaft Clavicle Template 18H R 120mm
7611-9911	EVOS 2.7mm Inferior Midshaft Clavicle Template 11H 120mm
7611-7508	EVOS 3.5mm Superior Medial Clavicle Template 8H 87mm
7611-9718	EVOS 2.7mm Superior Midshaft Clavicle Template 18H L 120mm
7611-8713	EVOS 2.7mm Superior Medial Clavicle Template 13H 87mm
7117-0437	EVOS SMALL Clavicle Template Tray
7117-0438	EVOS SMALL Clavicle Template Tray Lid

Cat. Item	Description
PreOperative Templates	
7612-5500	EVOS® 2.7mm Recon Plate Preoperative Template
7612-5501	EVOS 2.7mm Locking Recon Plate Preoperative Template
7612-5502	EVOS 2.7mm Compression Plate Preoperative Template
7612-5503	EVOS 2.7mm Locking Compression Plate Preoperative Template
7612-5504	EVOS 3.5mm Recon Plate Preoperative Template
7612-5505	EVOS 3.5mm Locking Recon Plate Preoperative Template
7612-5506	EVOS 3.5mm Compression Plate Preoperative Template
7612-5507	EVOS 3.5mm Locking Compression Plate Preoperative Template
7612-5508	EVOS 3.5mm 1/3 Tubular Plate Preoperative Template
7612-5509	EVOS 3.5mm Locking 1/3 Tubular Preoperative Template
7612-5510	EVOS 3.5mm Lateral Proximal Tibia Plate Preoperative Template
7612-5511	EVOS 3.5mm Partial Articular Lateral Proximal Tibia Preoperative Template
7612-5512	EVOS 3.5mm Medial Proximal Tibia Preoperative Template
7612-5513	EVOS 3.5mm Partial Articular Medial Proximal Tibia Preoperative Template
7612-5514	EVOS 3.5mm Partial Articular Posteromedial Proximal Tibia T Plate Preoperative Template
7612-5515	EVOS 3.5mm Partial Articular Posteromedial Proximal Tibia I Plate Preoperative Template
7612-5516	EVOS 3.5mm Posteromedial Proximal Tibia T Plate Preoperative Template
7612-5517	EVOS 2.7/3.5mm Partial Articular Medial Distal Tibia Preoperative Template
7612-5518	EVOS 2.7/3.5mm Partial Articular Posterior Distal Tibia Preoperative Template
7612-5519	EVOS 2.7mm Lateral Distal Fibula Plate Preoperative Template
7612-5520	EVOS 2.7/3.5mm Lateral Distal Fibula Plate Preoperative Template
7612-5521	EVOS 3.5mm Lateral Distal Fibula Plate Preoperative Template
7612-5522	EVOS 2.7/3.5mm Posterolateral Distal Fibula Plate Preoperative Template
7612-5523	EVOS 3.5mm Antiglides Posterolateral Distal Fibula Plate Preoperative Template
7612-5524	EVOS 2.7/3.5mm Partial Articular Anterior Distal Tibia Plate Preoperative Template
7612-5525	EVOS 3.5mm Posterior Distal Tibia Plate Preoperative Template
7612-5526	EVOS 2.7/3.5mm Medial Distal Tibia Plate Preoperative Template
7612-5527	EVOS 2.7/3.5mm Partial Articular Anterolateral Distal Tibia Plate Preoperative Template
7612-5528	EVOS 2.7/3.5mm Anterolateral Distal Tibia Plate Preoperative Template
7612-5529	EVOS 2.7/3.5mm Superior Distal Clavicle Plate Preoperative Template
7612-5530	EVOS 3.5mm Superior Medial Clavicle Plate Preoperative Template
7612-5531	EVOS 2.7mm Superior Medial Clavicle Plate Preoperative Template
7612-5532	EVOS 3.5mm Superior Midshaft Clavicle Plate Preoperative Template
7612-5533	EVOS® 2.7mm Superior Midshaft Clavicle Plate Preoperative Template
7612-5534	EVOS 2.7/3.5mm Inferior Distal Clavicle Plate Preoperative Template
7612-5535	EVOS 2.7/3.5mm Inferior Medial Clavicle Plate Preoperative Template
7612-5536	EVOS 2.7mm Inferior Distal Clavicle Plate Preoperative Template
7612-5537	EVOS 2.7mm Inferior Midshaft Clavicle Plate Preoperative Template
7612-5538	EVOS 3.5mm Curved Proximal Humerus Plate Preoperative Template
7612-5539	EVOS 3.5mm Straight Lateral Proximal Humerus Plate Preoperative Template
7612-5540	EVOS 3.5mm Greater Tuberosity Plate Preoperative Template
7612-5541	EVOS 2.7/3.5mm Extended Medial Distal Humerus Plate Preoperative Template
7612-5542	EVOS 2.7/3.5mm Medial Distal Humerus Plate Preoperative Template
7612-5543	EVOS 2.7/3.5mm Posterolateral Distal Humerus Plate Preoperative Template
7612-5544	EVOS 2.7/3.5mm Extra-Articular Posterolateral Distal Humerus Plate Preoperative Template
7612-5545	EVOS 2.7/3.5mm Lateral Distal Humerus Plate Preoperative Template
7612-5546	EVOS 2.7/3.5mm Olecranon With Tines Plate Preoperative Template
7612-5547	EVOS 2.7/3.5mm Olecranon Plate Preoperative Template
7612-5548	EVOS 3.5mm Curved Radial Shaft Plate Preoperative Template
7612-5549	EVOS 2.7/3.5mm Proximal Radius Plate Preoperative Template
7612-5550	EVOS 2.7/3.5mm Extra-Articular Volar Distal Radius Plate Preoperative Template
7612-5551	EVOS 2.7mm Cortex Screw Preoperative Template
7612-5552	EVOS 2.7mm Locking Screw Preoperative Template
7612-5553	EVOS 3.5mm Cortex Screw Preoperative Template
7612-5554	EVOS 3.5mm Locking Screw Preoperative Template
7612-5555	EVOS 4.7mm Fully Threaded Osteopenia Screw Preoperative Template
7612-5556	EVOS 4.7mm Partially Threaded Osteopenia Screw Preoperative Template
7612-5557	EVOS 4.7mm Locking Osteopenia Screw Preoperative Template
7612-5558	EVOS 4.0mm Fully Threaded Osteopenia Screw Preoperative Template
7612-5559	EVOS 4.0mm Partially Threaded Osteopenia Screw Preoperative Template

Supporting healthcare professionals for over 150 years

Smith & Nephew, Inc.
1450 Brooks Road
Memphis, TN 38116
USA

www.smith-nephew.com
Telephone: 1-901-396-2121
Information: 1-800-821-5700
Orders/Inquiries: 1-800-238-7538